

GENERAL INSTALLATION INFORMATION

To ensure maximum performance from your Stream33 bath fixture, please read and follow the instructions and cautions. Carefully inspect the new fixture for any shipping damage. If such damage is found, report it to your vendor immediately. Under no circumstances should a damaged fixture be installed. The manufacturer and its distributor are not responsible for removal or reinstallation costs if a replacement fixture is necessary due to installation of a damaged fixture. Do not make modifications to the bath fixture. This could adversely affect the safety and performance of the fixture and void the warranty. Any failure to comply with the installation instructions and cautions may void the warranty.

Items Included

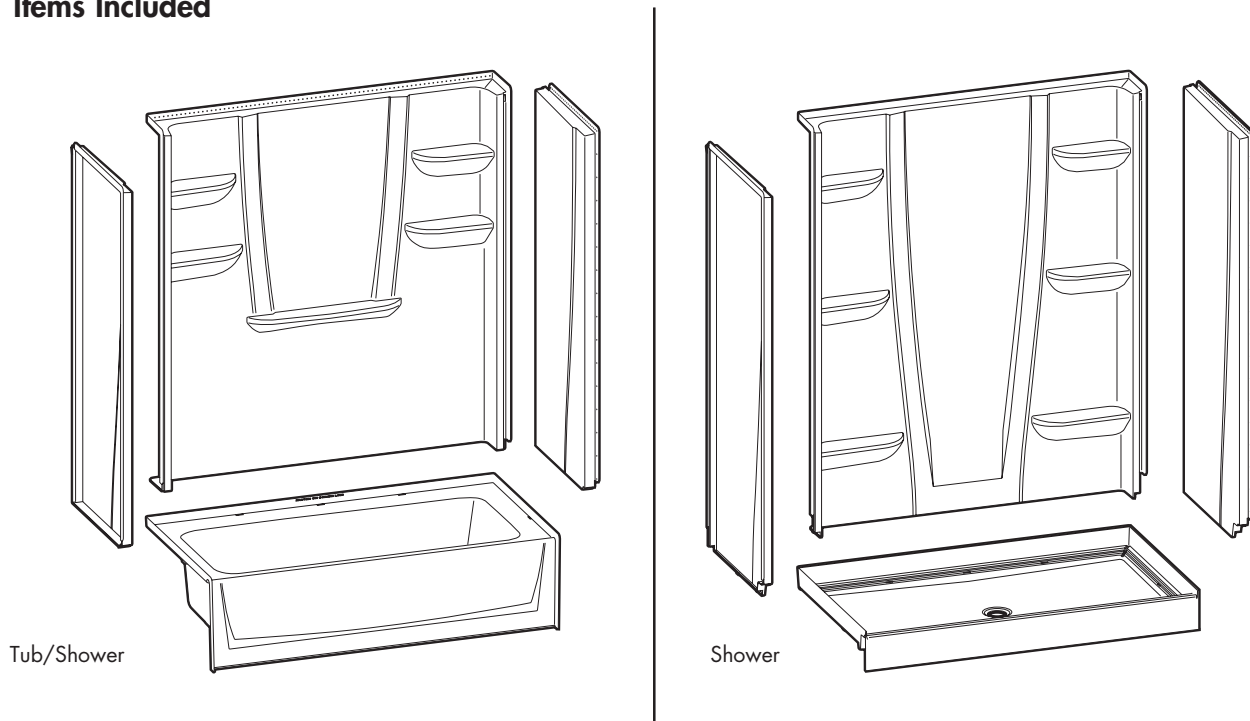

Tools Needed

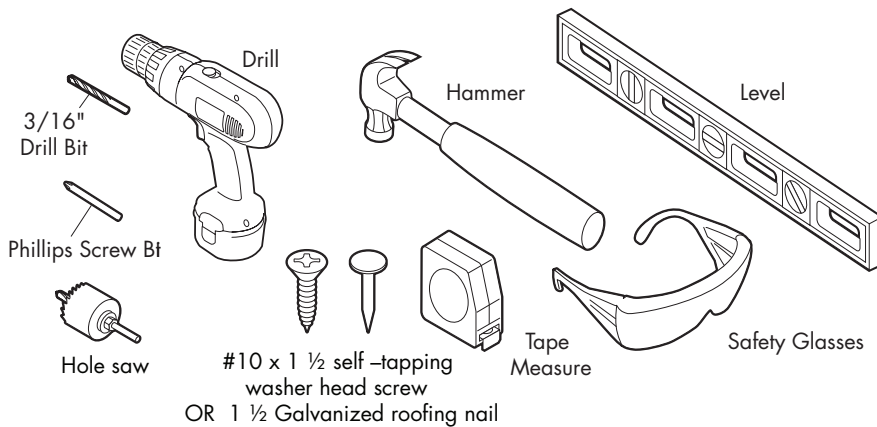

NOTE: Caulk is NOT needed for this installation.

PLEASE READ ALL INSTALLATION INSTRUCTIONS COMPLETELY BEFORE BEGINNING THE INSTALLATION.

PRE-INSTALLATION PLANNING

1. Review job print and rough-in dimensions; verify all key dimensions against actual job conditions. **MUST INSURE ROUGH DIMENSIONS ARE PROPER AND SQUARE.**
2. Locate studs as required and in remodeling, if necessary, add studs at each end to provide a vertical nailing surface for the side nailing flanges of the fixture.
3. Make sure framed-in framing pocket is of proper size, square and plumb; check floor for level. Some shimming between the stud frame and fixture may be required.
4. **DO NOT** install the product over open floor joist. Product should not require any additional support if the subfloor is square and level with framing. Shimming or foundation material may be required for additional support, if subfloor is uneven.
5. If fire-rated framing pocket is required, approved finish material must be in place prior to unit installation to meet fire safety requirements of local building code and/or FHA/HUD Minimum Property Standards.
NOTE: Finished framing pocket must have interior dimensions shown on rough-in diagram to permit installation of unit.
6. Foundation material is not required.
7. Provide 6" (150mm) floor opening for 2" (50mm) IPS and drain connection.
8. To ensure proper installation of the fixture, all local plumbing and building codes must be observed. Local building codes vary by location and you are responsible for insuring plumbing is complete and to code.
9. To avoid obstruction, make sure that supply lines and valve plumbing do not project into framing pocket during the installation process. Also, drain pipe must not project above floor level prior to installation.
10. On inside of plumbing wet wall of unit, note location of supply elbow and mixer valve. (See "Tub and Shower Mounted Fittings" below.)
11. To prevent scuffing while installing unit, cover the floor of the unit with a piece of cardboard or other protective material.
12. Fasteners for:
Wood framing – 1 1/2" galvanized roofing nails or #10 x 1 1/2" self-tapping washer head screws. Concrete or block walls – 1" concrete nails and nailing tool.
Steel studs (18 ga.) – drill flanges and studs with 5/32" carbide bit and use #12 x 1" sheet metal screws.
NOTE: Always pre-drill no matter what fastener is to be used.
13. If installing shower door refer to the shower door manufacturers installation instructions for any special considerations.
14. NOTE: Where local codes specify minimum door openings, shower stalls may require swing doors. (Sliding doors may not provide a wide enough opening.)
15. S33A2-3232CS does not carry UPC seal and is not approved by some municipal plumbing codes due to inside dimensions. Check local building codes.

Tub and Shower Mounted Fittings: If mounting fittings on tub or shower, from stable reference points (back wall studs, floor), measure the locations of spout and valves. Note measurements:

Tub Filler: _____ Valve: _____

Shower Arm: _____ Valve: _____

(Mark dimensions only if shower arm is plumbed within bath fixture wall area.)

INSTALLATION PROCEDURE

1A

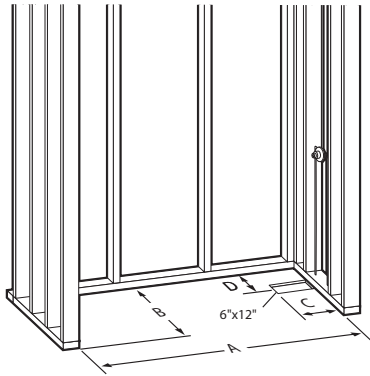

1B

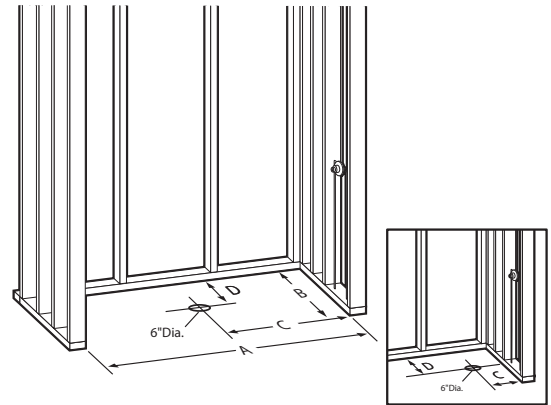

Check dimensions. For tub-showers, refer to Diagram 1A; for showers, refer to Diagram 1B.

NOTE: If you're adding additional accessories such as a grab bar—additional framing may be needed for support.

2

Models	A	B	C	D
S33A2-6030CT/CTM	60"	31¼"	2⅞"	14¼"
S33A2-6030CTMIN/MM	60"	31½"	2¾"	14⅝"
S33A2-6032CMIN/MM	60"	33½"	2¾"	15¾"
S33A2-6036CT/CTM	60"	37½"	2"	17⅜"
S33A2-6042CT/CTM	60"	43½"	2"	20⅝"
S33A2-3232CPAN	32"	32"	16"	15½"
S33A2-3636CPAN	36"	36"	18"	17½"
S33A2-4834CPAN	48"	34"	24"	16½"
S33A2-6034CPAN	60"	34"	30"	16½"
S33A2-6030CPAN	60"	30"	8½"	14"

3

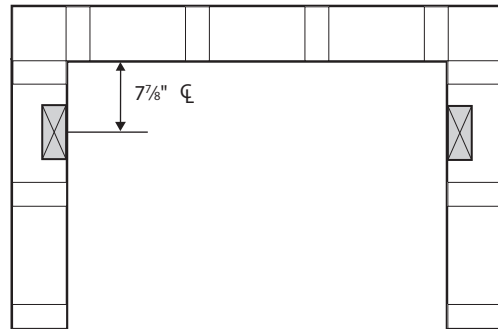

Pre-install unit to ensure framing pocket is plumb, square and a level installation can be achieved (see steps 3 through 9).

Adjust framing as needed – Shim where necessary.

*Review Tech Data at stream33.com for more detail.
Note: S33A2-6030CTS is shown for illustrational purposes.

Additional stud may be required for vertical backwall flange. Stud @ 7⅞" CL from back, on both sides. Stud can be turned for easier installation.

4

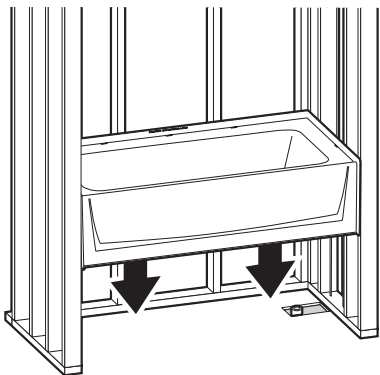

Lift and place the base into framing.

5

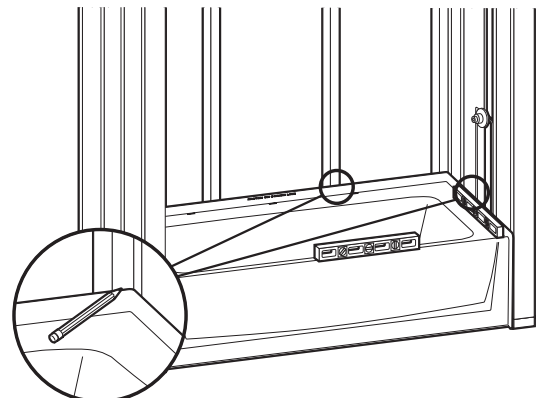

Level and mark all sides. Front apron should be firmly on the floor.

INSTALLATION PROCEDURE, CONT.

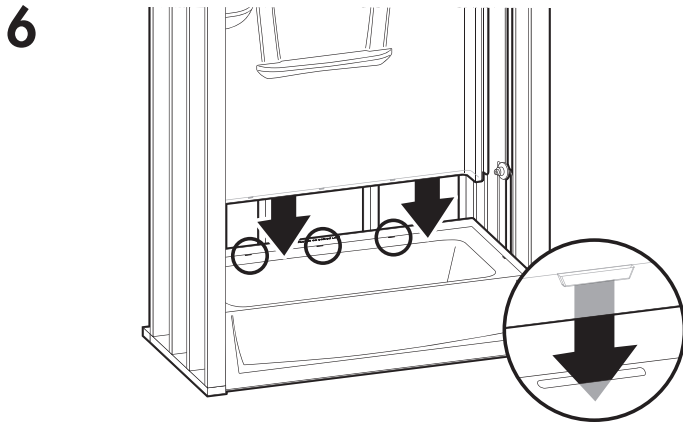

Lift and place the back wall, making sure locking tabs are engaged.

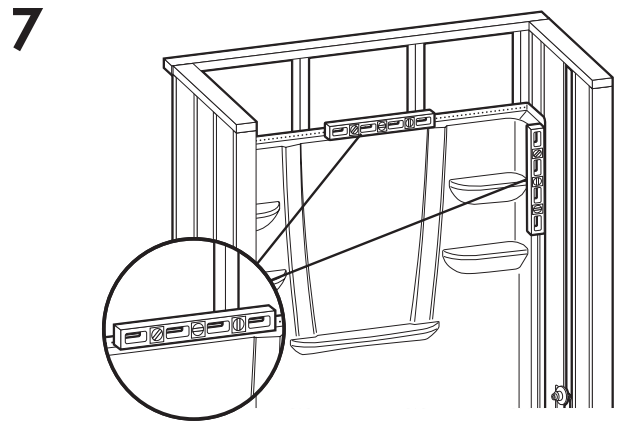

Level back wall vertically & horizontally. Shim if necessary.

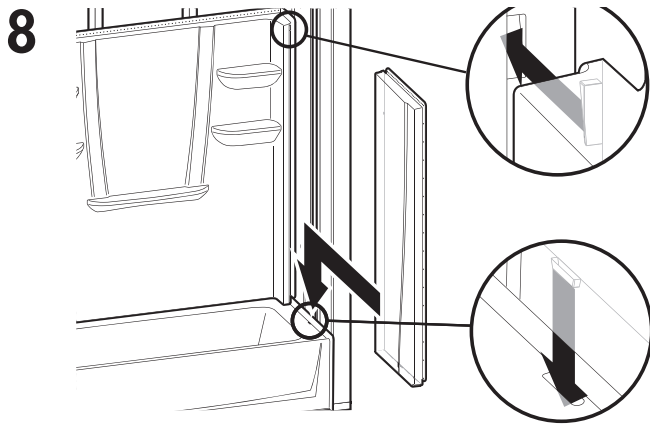

Slide right side wall into position. Be sure locking mechanism is engaged.

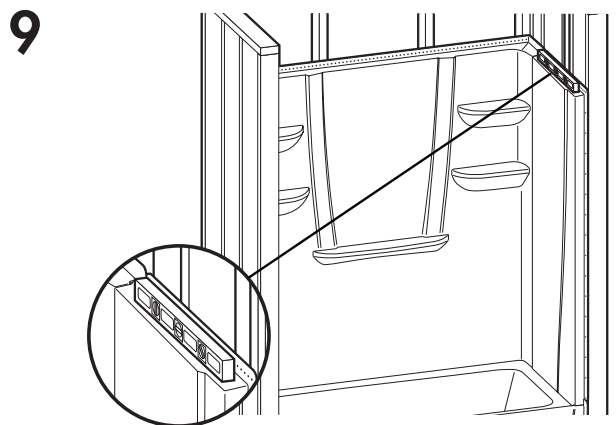

Check for level. Shim if necessary.

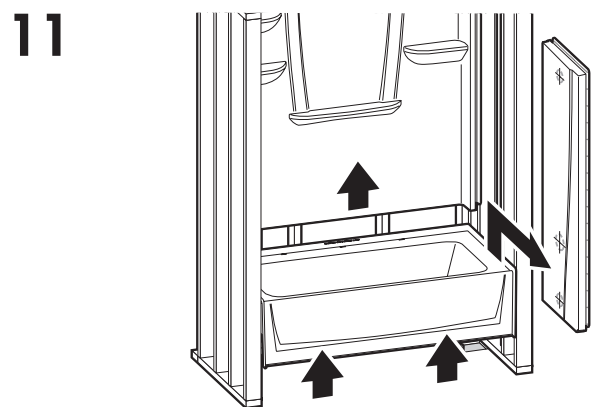
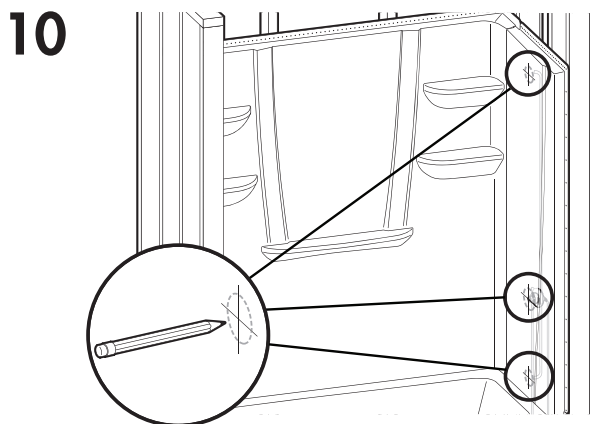

INSTALLATION PROCEDURE, CONT.

12

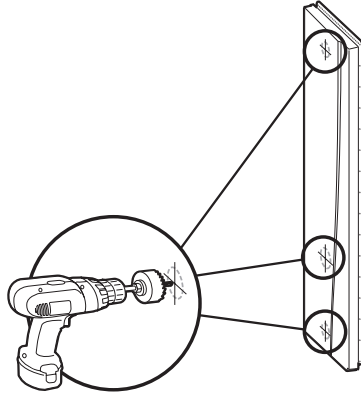

Using a hole saw (fine tooth or abrasive grit cutting edge), make necessary openings for filler and valves, drilling from inside (smooth side) out.

13

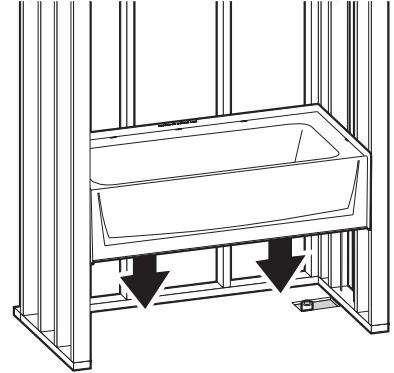

Install drain assembly per manufacturer's instructions. Place base into framing pocket.

14

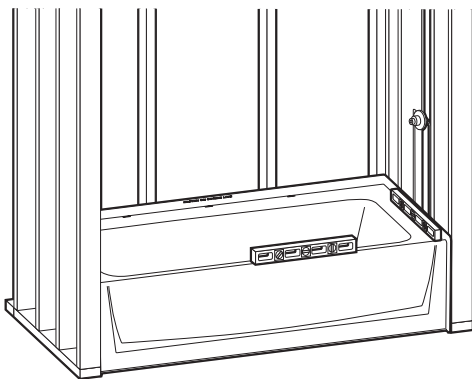

Level lengthwise and widthwise using 3 ft. (915mm) level by shimming if necessary. The unit must be set level.

15

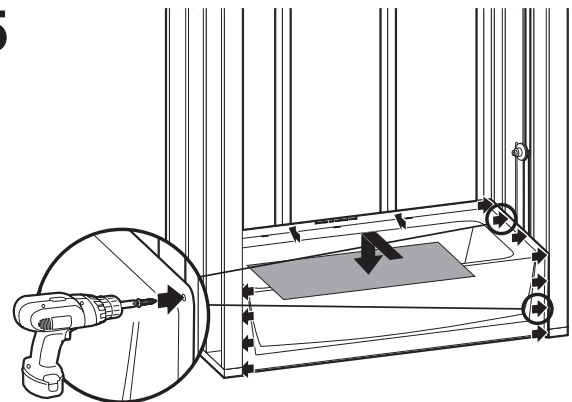

Pre-drill horizontal flanges along top of base section and fasten into each corresponding stud. Pre-drill both (vertical) side flanges and fasten to side studs 8" (200mm) on center. Place cardboard to protect finish.

16

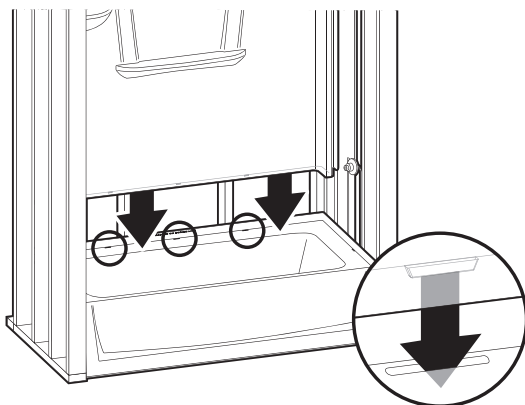

Lift and place back wall, making sure locking tab is engaged.

17

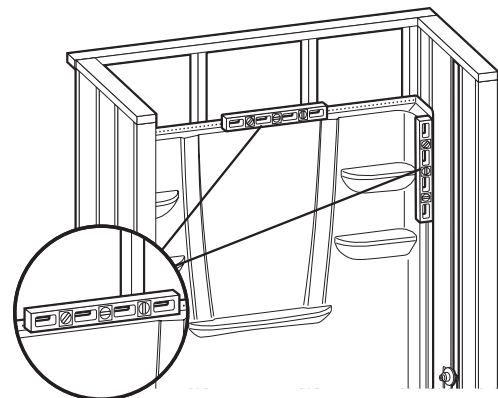

Level back wall vertically & horizontally. Shim if necessary.

INSTALLATION PROCEDURE, CONT.

18

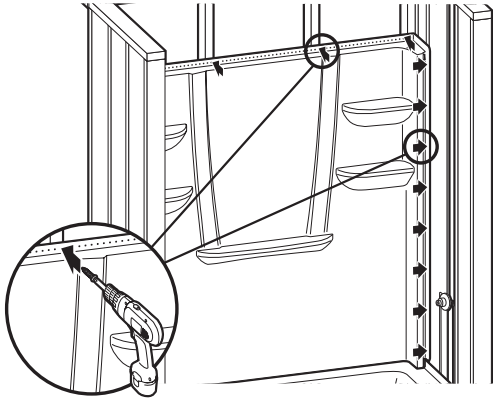

Fasten flanges along top of back wall with fasteners of choice (see Pre-Installation Planning #12) into each corresponding stud. Pre-drill both (vertical) side flanges and nail fasten to side studs 8" (200mm) on center. **NOTE:** A stud should be added if adding accessories. Must have at least 1 fire block to secure vertically.

19

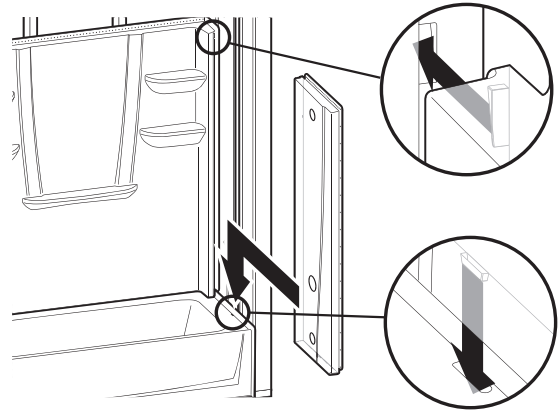

Slide right side wall into position. Be sure locking mechanism is engaged. **NOTE:** Finish Caulking is not required, however, if using caulk, weep channel must remain clear of obstruction to allow for proper drainage of the unit.

20

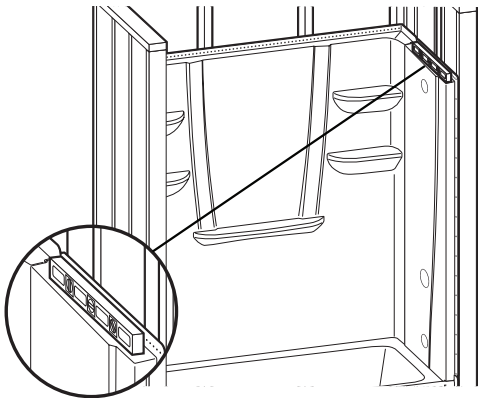

Check for level. Shim if necessary.

NOTE: To accommodate any stud variation, you may have to add a bead of waterproof adhesive such as 100% silicone to eliminate any potential free play.

21

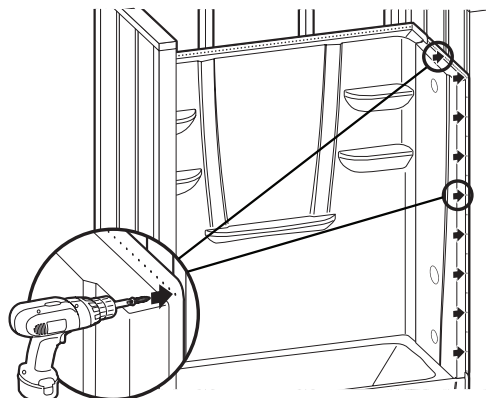

Fasten flanges along top of right side wall with fasteners of choice (see Pre-Installation Planning #12) into each corresponding stud. Fasten side (vertical) flanges to side studs 8" (200mm) on center.

INSTALLATION PROCEDURE, CONT.

22

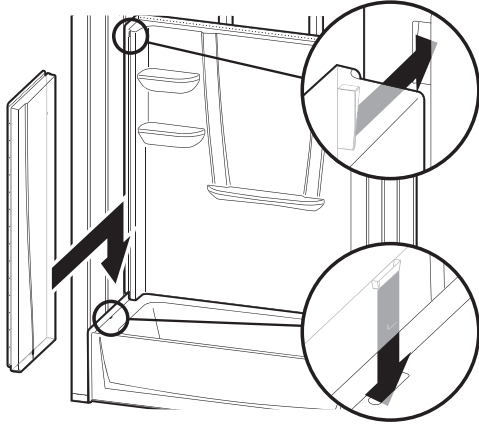

Slide left side wall into position. Be sure locking mechanism is engaged.
NOTE: To accommodate any stud variation, you may have to add a bead of waterproof adhesive such as 100% silicone to eliminate any potential free play.

23

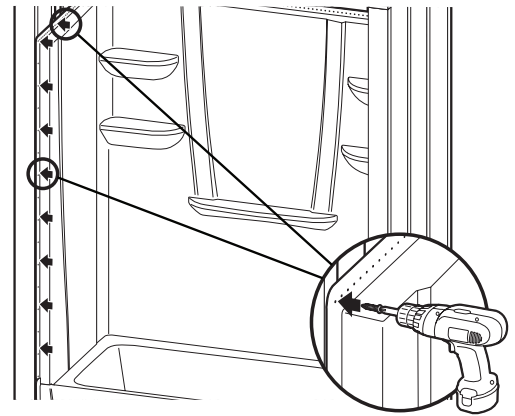

Fasten flanges along top of left side wall with fasteners of choice (see Pre-Installation Planning #12) into each corresponding stud. Fasten side (vertical) flanges to side studs 8" (200mm) on center.

NOTE: Finish Caulking is not required, however, if using caulk, weep channel must remain clear of obstruction to allow for proper drainage of the unit.

CLEAN-UP

CAUTION: SOME CLEANING PRODUCTS ARE NOT SUITABLE FOR USE. READ ALL LABELS CAREFULLY. DO NOT USE if labels say heat or solvent based cleaning fluids.

NOTE: Do not remove warranty/maintenance adhered label. Warranty/User maintenance label must be left for occupant (Required by ANSIZ124).

1. To prevent staining, remove all debris before plumbing leak test. Drain and wipe clean immediately after the inspection process. Use sponge with warm water and liquid detergent. Rinse, drain and wipe clean. Do not use abrasive cleansers that might mar, dull or scratch the finish such as scouring powders, steel wool, metal scrapers, or sandpaper.
2. If drywall mud or plaster gets on your fixture, it may be carefully removed with a wooden scraper. Roofing tar or paints may be removed with rubbing alcohol or paint thinner. Lacquer thinner should never be used on the fixture.
3. Plaster and latex paint may be removed with warm water, liquid detergent and brittle brush or plastic scraper. Do not use metal scraper or utensil to remove plaster or paint from finish.
4. Dull areas and light scratches can be restored to high gloss by buffing with a soft cloth with white or cream-colored automotive rubbing compound, followed by the application of coat or good quality white automotive polish (or similar) and buff with a soft cloth. DO NOT WAX standing surfaces of the unit bottom (this includes textured, slip resistant standing surfaces), which could result in greater risk of slipping and personal injury.
5. Major gouges require professional repair.
6. See user maintenance instructions and label for more details.

USER MAINTENANCE INSTRUCTIONS

IMPORTANT! Use only recommended cleaners and procedures described herein. Use of other materials and methods may damage your bath fixture and void the warranty.

1. For normal cleaning, never use abrasive cleaners such as scouring powders or pads, steel wool, scrapers, sandpaper or anything else that could scratch or dull the surface of your fixture. Use warm water and liquid detergents or non-abrasive cleansers, such as Soft Scrub Gel or Comet Gel. Read all labels carefully and DO NOT USE if they say "not suitable for use with fiberglass."
2. To keep your fixture sparkling clean, apply a coat of good quality automotive paste wax or polish and buff to a high shine with a soft cloth or towel. Repeat every six months for easier cleaning and long lasting protection. DO NOT WAX standing surfaces of the unit bottom (this includes textured, slip resistant standing surfaces), which could result in greater risk of slipping and personal injury.
3. To restore a scratched or dull unit, use an automotive polishing compound applied with a clean cotton rag. Rub scratches and dull areas vigorously. Wipe off residues. Follow with automotive wax treatment described above. DO NOT WAX standing surfaces of the unit bottom (this includes textured, slip resistant standing surfaces), which could result in greater risk of slipping and personal injury.
4. To remove adhesive, try 3-M[®] natural cleaner, De-Solv-It[®] or similar materials. If residues remain, saturate small white cotton rag with nail polish remover and rub vigorously until the adhesive dissolves and disappears. These solvents are highly flammable and must be used sparingly and with caution. Do not allow solvent to go down the drain. Make sure not to contact plastic drain grates or other synthetic materials.
5. Rubber mats: If you use rubber "anti-skid" mat, make sure to remove it from the unit after each use to avoid harm to the surface finish.
6. Hard Water: Water in certain regions, if not wiped up after bathing/showering, may cause fading of some fixture colors. This is a natural occurrence beyond the manufacturer's control and the manufacturer is not responsible for any fading caused from hard water. (See Warranty)

CAUTION: When using any cleaning or polishing materials, make sure to read and follow all package instructions carefully. Wear rubber gloves at all times and avoid contact with eyes, skin, clothing, rugs and furnishings. Make sure all residues are rinsed off thoroughly.