

Heat Pump Water Heater  
**USE & CARE MANUAL**

With Installation Instructions for the Installer



**REGISTER YOUR PRODUCT**

After you register your product, you can find the warranty on the back.

**Warning: DO NOT** destroy or lose this manual. Please read the manual thoroughly. Store manual for easy retrieval as a future reference. As a result of product improvement, specification and design of this water heater are subject to change without advanced notice. Consult your manufacturer or your dealer for details concerning your product. The diagram pictured on front cover is a reference image; please take the appearance of the actual product as the standard.

# CONTENTS

**INTENDED USE**.....2

**SAFETY INSTRUCTIONS**.....3

**SPECIFICATION SHEET**.....8

**INSTALLATION INSTRUCTIONS** .....9

**OPERATING INSTRUCTIONS**.....18

**CARE & CLEANING**.....21

**TROUBLESHOOTING TIPS**.....23

**CUSTOMER SERVICE**.....31

## Intended Use

This manual will provide the installer with recommendations and basic instructions for the proper installation and adjustment of the water heater. This manual will explain to the owner-operator: the features, operations, safety precautions, maintenance, and troubleshooting steps of the water heater. This manual includes a replacement parts list.

The instructions must be read carefully by the owner-operator to ensure that they can adjust the water heater or operate the water heater proficiently. Please seek professional advice if you find that you do not understand the instructions.

For addition questions regarding service, warranty, and maintenance that are not covered by these instructions, please contact the seller from whom your product was purchased.

# SAFETY INSTRUCTIONS

## For Your Records

Write the model and serial numbers here:

# \_\_\_\_\_

# \_\_\_\_\_

Check rating label on the front of your water heater for these numbers.

Keep track of sales slip and proof of original purchase. This evidence is needed by owner to obtain service under warranty.

## Read This Manual

Preventative care by owner can maximize the life of the water heater. Please refer to **CARE & CLEANING** section and **TROUBLESHOOTING TIPS** section. This may prevent you from making a service call for your unit.

## Read The Safety Information

Your safety is important. The safety of others is important. There are important safety messages in this manual and for your water heater. Obey all safety messages.



Located to the left is a symbol for safety alert. That symbol indicates Important Safety Information regarding potential hazards that can cause harm or death to you and others.

Please see explanation of symbols below for “DANGER”, “WARNING”, “CAUTION” or “NOTICE”.

## Explanation of symbols



### DANGER

This represents a serious hazard that must be taken seriously to avoid death or injury to yourself and others.



### WARNING

This represents a potentially hazardous situation. Warnings should be noted so that users can avoid situations that could result in damage to property and/or death or serious injury.



### CAUTION

This symbol indicates owner/user should take care to avoid minor or moderate injury in a potentially harmful situation.



### NOTICE

This symbol is to indicate that attention should be directed towards a specified procedure or maintain a specific condition.

## Important Safety Information - Read All Instructions Before Using

### DANGER - WATER TEMPERATURE SETTING

Please consider safety and energy conservation when selecting the water temperature setting of water heater.

Severe burns can occur from hot water.

In extreme cases, death from scalding can occur. As owner-operator, be sure to read and follow the warnings outlined on the label pictured right. This label is also located on the water heater.

#### NOTICE

It is possible to reduce point of use water temperature with a mixing valve. The way that mixing valves work is that they mix hot and cold water in branch water lines. Please note that this product does not include a mixing valve. During installation and use, it is necessary to purchase and install a mixing valve separately. It is recommended that a mixing valve complying with the Standard for Temperature Actuated Mixing Valves for Hot Water Distribution Systems, ASSE 1017 is purchased before being installed. See page 32 for more details. For assistance, please contact a licensed plumber for further information.

To use demand response for your water heater, use a thermostatic mixing valve (that conforms to ASSE 1017) on the hot water supply line following instructions.

If the SUPPLY CORD is damaged, it must be replaced by the manufacturer, its service agent or similarly qualified person in order to avoid a hazard.

Heat Pump Strictest operation environment: 37°F~107°F (3°C~42°C). Heating element Strictest operation environment: 5°F~114°F (-15°C~46°C). Strictest operation environment: 5°F~114°F (-15°C~46°C). Temperature can set range is 109°F~149°F (43°C~65°C).

The vent shall not be obstructed.

 **DANGER**



This water heater can make water hot enough to cause severe burns instantly, resulting in severe injury or death. Be careful to have children, disabled and elderly not exposed to scald risk. Before setting temperature at water heater, see instruction manual. Test water temperature before bathing or showering. Refer to manual for temperature limiting valves reference.

### Time/Temperature Relationship in Scalds

Temperature	Time To Produce a Serious Burn
120°F (49°C)	More than 5 minutes
125°F (52°C)	1-1/2 to 2 minutes
130°F (54°C)	About 30 seconds
135°F (57°C)	About 10 seconds
140°F (60°C)	Less than 6 seconds
145°F (63°C)	Less than 3 seconds
150°F (65°C)	About 1-1/2 seconds
155°F (68°C)	About 1 second

*Table courtesy of Shriners Burn Institute*

The guide above shows how fast it is possible to be scalded based on the output temperature of the water. Use this guide to determine the proper water temperature for your home.

### DANGER

This appliance not intended for use by persons (including children) with reduced physical, sensory or mental capabilities, or lack of experience and knowledge, unless they have been given supervision or instruction concerning use of the appliance by a person responsible for their safety.

For more information visit [stream33.com](http://stream33.com)

Children should be supervised to ensure that they do not play with the appliance. Before the water heater is shipped from the factory, it was set to a temperature of 120 °F (49°C) to reduce the risk of scald injury. This is done to comply with safety regulations. Refer to illustration below, which shows the water temperature setting. Refer to the Operating instructions on Page 19 in this manual for detailed instructions in how to adjust the water temperature.

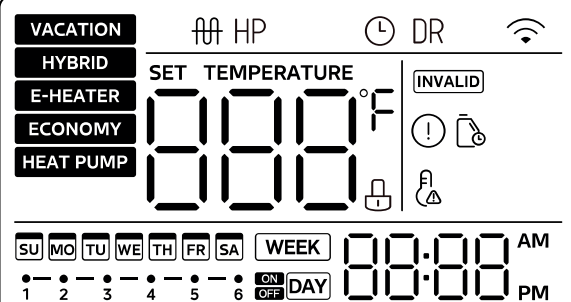

### DANGER

It is important to note that higher temperatures of water increases scald risk.

## Relief Valve Warnings

### Safety Devices

Temperature sensors, overheat sensors and switches and a Pressure & Temperature Relief (PTR) valve are supplied for the water heating system.

- DO NOT tamper with these device.
- DO NOT remove these devices.
- DO NOT seal the PTR Valve or drain pipe.
- DO NOT operate the system unless each device is properly fitted.

### Pressure & Temperature Relief (PTR) Valve

Please note that this valve is located near the top of the water heater and is essential for safe operation. It is normal for the valve to release a small quantity of water through the drain line during heating.

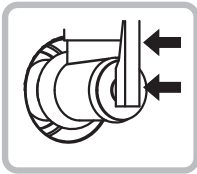

Lower lever carefully until water flows from drain line.



**BATTERY WARNING**



**WARNING:**  
Contains coin battery.

### **WARNING**

**INGESTION HAZARD:** This product contains a button cell or coin battery.

- **BATTERY WARNING: KEEP OUT OF REACH OF CHILDREN;**
- If the battery compartment (if applicable) does not close securely, stop using the product and keep it away from children.
- If you think batteries might have been swallowed or placed inside any part of the body, seek immediate medical attention.

### **WARNING**

- **INGESTION HAZARD:** This product contains a button cell or coin battery.
- **DEATH** or serious injury can occur if ingested.
- A swallowed button cell or coin battery can cause **Internal Chemical Burns** in as little as **2 hours**.
- **KEEP** new and used batteries **OUT OF REACH OF CHILDREN**.
- **Seek immediate medical attention if a battery** is suspected to be swallowed or inserted inside any part of the body.



### **BATTERY WARNING**

**KEEP OUT OF REACH OF CHILDREN.** Swallowing can lead to chemical burns, perforation of soft tissue, and death. Severe burns can occur within 2 hours of ingestion. Seek medical attention immediately.



### **WARNING**

- Remove and immediately recycle or dispose of used batteries according to local regulations and keep away from children. Do not dispose of batteries in household trash or incinerate.
- Even used batteries may cause severe injury or death.
- Call a local poison control center for treatment information.
- Non-rechargeable batteries are not to be recharged.
- Do not force discharge, recharge, disassemble, heat above -4-158°F (-20-70 °C) or incinerate. Doing so may result in injury due to venting, leakage or explosion resulting in chemical burns.
- Ensure the batteries are installed correctly according to polarity (+ and -).
- Do not mix old and new batteries, different brands or types of batteries, such as alkaline, carbon-zinc, or rechargeable batteries.
- Remove and immediately recycle or dispose of batteries from equipment not used for an extended period of time according to local regulations.
- Always completely secure the battery compartment. If the battery compartment does not close securely, stop using the product, remove the batteries, and keep them away from children.
- Battery type: CR2032
- Battery nominal voltage: 3.0 V

### **WARNING**

- DO NOT remove safety devices or tamper with them.
- ENSURE that all safety devices are fitted and in working order BEFORE operating the water heater.
- The PTR Valve and drain pipe MUST NOT be block or sealed in any way.
- The PTR valve or its drain must NEVER be blocked for any reason. Every 6 months the easing gear MUST be operated in order to verify that they are not blocked and to remove lime deposits. Water heater may fail if these steps are not followed.
- Contact local plumber without delay if the PTR valve does (1) not discharge water when the easing gear lever is opened, or (2) does not seal again when the easing gear is closed. The PTR valve is not serviceable and must be replaced if damaged.

## Excessive Discharge From Safety Devices

### Pressure & Temperature Relief (PTR) Valve (Required) and Expansion Control Valve (ECV)-(If Required)

- A small quantity of water will discharge from the PTR valve during normal operation during the heating cycle of the water heater. Continuous and ongoing leakage of water from the valve and its drain line may indicate a problem with the water heater.
- If the valve leaks continuously but not by a large amount, then there may be foreign matter inside the valve. Locate a bucket to place under valve and ease the valve gear for a few seconds to dislodge the debris.

HOWEVER, if the valve discharges at high flow this may be because the water pressure is exceeding the design pressure of the water heater. Ask your installer or local plumber to heater fit a Pressure Limiting Valve (PLV).

## WARNING

In order to minimize the risk of fire or explosion, electric shock, or to prevent property damage, personal injury, or loss of life, please follow the information in this manual. Before attempting to install or operate this water heater, be sure to read and understand the entire Use and Care Manual.

STOP if you have any issues understanding the instructions in this manual and get help from a local plumber, local plumbing authority, local electric utility, or qualified service technician.

## Safety Precautions



- Know the location of the circuit breaker and how to shut it off if necessary. If you cannot find the circuit breaker, ask the installer to locate it for you. Should the water heater be subjected to overheating, fire, flood physical damage or if the ECO (temperature limiting control) fails to shut off, turn off the circuit breaker IMMEDIATELY.
- Local codes and the provided installation instructions should be used to ensure your appliance is properly installed.
- Servicing should be referred to a qualified technician. DO NOT repair or replace any part of your water heater unless it is specifically recommended in this manual.
- DO NOT attempt to repair any part associated with the sealed refrigerant system.
- MAKE SURE the water heater is completely filled with water BEFORE turning on the electrical supply.



## CAUTION

In order to avoid a hazard due to inadvertent resetting of the THERMAL CUT-OUT, this appliance must not be supplied through an external switching device, such as a timer, or connected to a circuit that is regularly switched on and off by the utility.



## WARNING

BEFORE starting maintenance, disconnect all power to unit in order to avoid electrical shock resulting in severe personal injury or death.

A water heater equipped with an adjustable temperature-regulating control shall be provided with instructions that: Inform the user that the thermostat, as applicable, has been set at the factory to 120°F (49°C) or lower, to reduce the risk of scald injury (For CNU -factory set to 140°F (60.0°C)).



## WARNING

COMPRESSOR IS NOT SERVICEABLE; DO NOT ATTEMPT TO SERVICE COMPRESSOR.

The pressurized refrigerant and oil can escape if the compressor wiring terminals arc. This can cause the compressor to ignite and cause serious bodily injury, severe burns or death.



## WARNING

DO NOT EVER replace the PTR valve with one which has a higher pressure rating than is specified for your water heater; This can result in damage to the water heater and create unsafe conditions.

## Read And Follow This Safety Information Carefully



### NOTICE

SAVE THESE INSTRUCTIONS.

## **⚠️ WARNING**

When using electrical appliances, basic safety precautions to reduce the risk of fire, electric shock, or injury to persons should be followed, including: **READ ALL INSTRUCTIONS BEFORE USING THIS WATER HEATER.** This water heater must be grounded. Connect only to properly grounded outlet. See "GROUNDING INSTRUCTIONS" page 16.

Install or locate this water heater only in accordance with the provided installation instructions.

Use this water heater only for its intended use as described in this manual.

As with any appliance, close supervision is necessary when used by children.

This water heater should be serviced only by qualified service personnel. Contact nearest authorized service facility for examination, repair, or adjustment.

Do not use multi-outlet adapters (i.e. power strips) with this water heater.

### **Refrigerant**

This Hybrid Water Heater is factory charged with R134a; do not attempt to service refrigerant.

## **Operating Principle**

The electric heat pump operation is a reverse of a refrigerator's operation. The heat pump transfers heat from the ambient outside air into the water. Electricity is only used to operate the system.

The heat pump system will be more efficient at heating water during warmer ambient conditions.

There is a micro-channel heat exchanger wrapped around the inner cylinder; this is to allow for thermal conductivity between the refrigerant in the tank. A suitable tank temperature is achieved by using a temperature sensor in the tank.

In the event that ambient weather conditions are not suitable for the heat pump to operate, the electric element will provide heating to ensure operator-owner will have a supply of hot water.

## **System Schematic**

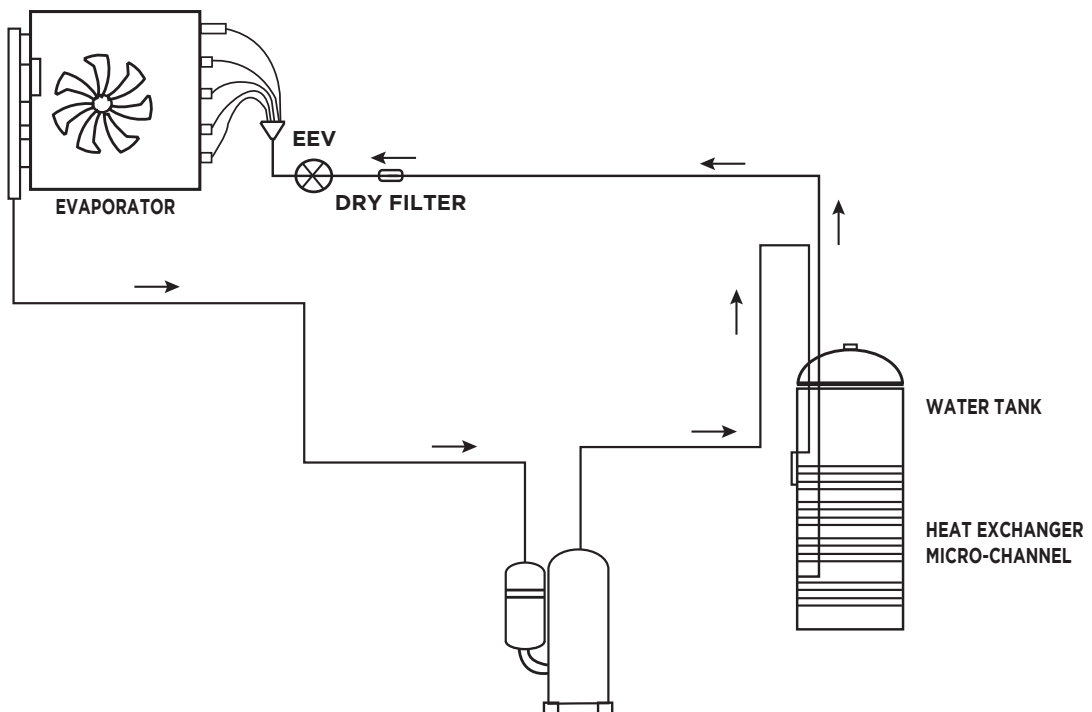

*\*Figure shown is for reference only, and may differ from actual system.*

# SPECIFICATION SHEET

This specification sheet is based on the ductless version of the appliance.

Description	Model Number		S33-HPWH50	S33-HPWH80
	Normal Gallon Capacity		50	80
	Rated Gallon Capacity		47	75
	Voltage		208V/240V, 60Hz, 1Ph	208V/240V, 60Hz, 1Ph
	Water Outlet Temperature Range		109F~149F	109F~149F
Energy Info	Uniform Energy Factor (UEF)		3.75	4.00
	First Hour Rating (FHR)		69	91
	Element Wattage	Upper	4500W(240V)	4500W(240V)
		Lower	4500W(240V)	4500W(240V)
	Compressor capacity		1500W	1500W
	Total Unit Wattage (input)		5500W	5500W
	Cold Climate Efficiency(CCE)		3	3
	Recovery In G.P.H. 90°F Rise		27.5	27.5
	Heat pump ambient operating range		37F~109F	37F~109F
	Heating element ambient operating range		5F~115F	5F~115F
Features	LED Screen		√	√
	WiFi-Ready		✘	✘
	Built-in CTA-2045 Port		√	√
	8" inlet & outlet air duct connection		Optional	Optional
	Operation Modes		5	5
	TP Valve installed		√	√
	Min. Circuit Amps		23.6A(208V)/26.8A(240V)	23.6A(208V)/26.8A(240V)
	Electric Breaker Size		25A(208V)/30A(240V)	25A(208V)/30A(240V)
	Replaceable Filter		√	√
	Installation Clearance (Back)		0"	0"
	Installation Clearance (Side)		6"	6"
	Installation Clearance (Top)		20"	20"
Dry Fire Protection		√	√	
Dimensions	Body Height		66 4/5 inch	74 3/5 inch
	Body Diameter		21 9/10 inch	25 7/10 inch
	Body Weight		218.26 lb	293.22 lb
	Ship Length		28 7/10 inch × 27 3/5 inch	30 3/10 inch × 29 1/10 inch
	Ship Height		75 1/5 inch	83 2/5 inch
	Ship Weight		264.56 lb	357.15 lb
	Water Connection Size	Inlet	3/4inch	3/4inch
		Outlet	3/4inch	3/4inch
Drainage Hose		3/4inch	3/4inch	
Certifications	UL 60335-1 & UL 60335-2-40		√	√
	UL 174		√	√
	AHRI		√	√
	NEEA		Tier 4	Tier 4
	NSF/ANSI 372		√	√
	Energy Star		√	√
Sound	NEEA test protocol		49.5dB(A)	49.5dB(A)

# INSTALLATION INSTRUCTIONS

The location chosen for the water heater must take into consideration the following:

## Local Installation Regulations

Follow the instructions in this manual, local codes, utility codes, utility company requirements or, in the absence of local codes, the latest edition of the National Electrical Code while installing this water heater. These materials are available from some local libraries. These materials can also be purchased from the National Fire Protection Association, Batterymarch Park, Quincy, MA 02269 as booklet ANSI/NFPA 70. For Canadian owners, please refer to Canadian Standards Association, 5050 Spectrum Way, Mississauga, ONT L4W 5N6 to purchase standard CSA22.1.

Installation should be avoided in an environment where flammable and explosive gases are leaking or where there are strong corrosive gases.

## Location

Locate a clean dry area for your water heater and position it as near as practical to the area of greatest heated water demand. Please understand that long uninsulated hot water lines can waste energy and water.

Ensure that the thermistor and element access panels can be removed when choosing a location for the water heater. This is to permit inspection and servicing such as removal of elements or checking controls.

Protect the water heater and water lines from freezing temperatures, AVOID installing the water heater in outdoor, unprotected areas.

The floor underneath the water heater MUST be strong enough to support the weight of the water heater after being completely filled with water. Where applicable, install a floor isolation kit is recommended to minimize vibrations.

## CAUTION

The Water Heater should not be located in an area where leakage of the tank or connections will result in damage to the area adjacent to it or to lower floors of the structure. Where such areas cannot be avoided, it is recommended that a suitable drain pan, adequately drained, be installed under the water heater.

## NOTICE

If adequate ventilation is not provided for installs inside confined spaces, the unit will have higher power consumption.

DO NOT install the hybrid water where ambient temperatures Exceed 114°F (46°C)

Clearances		
Rear	Sides	Top
0"	6"	20"

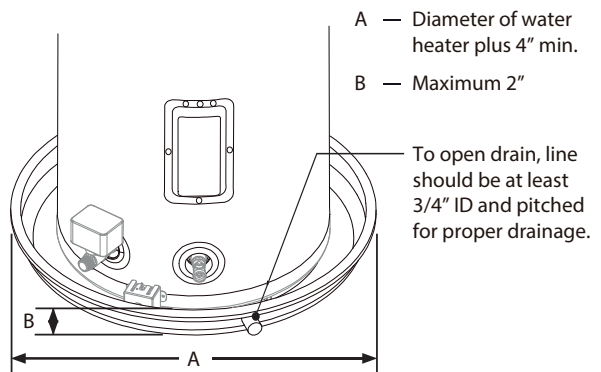

## NOTICE

ENSURE that the auxiliary drain pan conforms to local codes.

Purchase drain pan kits from the store where the water heater was purchased, or any water heater distributor. ENSURE that the drain pan DOES NOT obstruct cold inlet or drain valve.

## Inspect Shipment

Check the water heater for possible shipping damage after receiving the unit. Be certain that the power supply corresponds to the water heater requirements by checking the marking on the rating plate. Rating plate is located on front of water heater.

The clearance requirements of this water heater as follows:

Minimum Required Clearances			
Back	Left Side	Right Side	Top
0	0	6"	20"

This installation clearance is required for both 50 and 80 gallon heaters

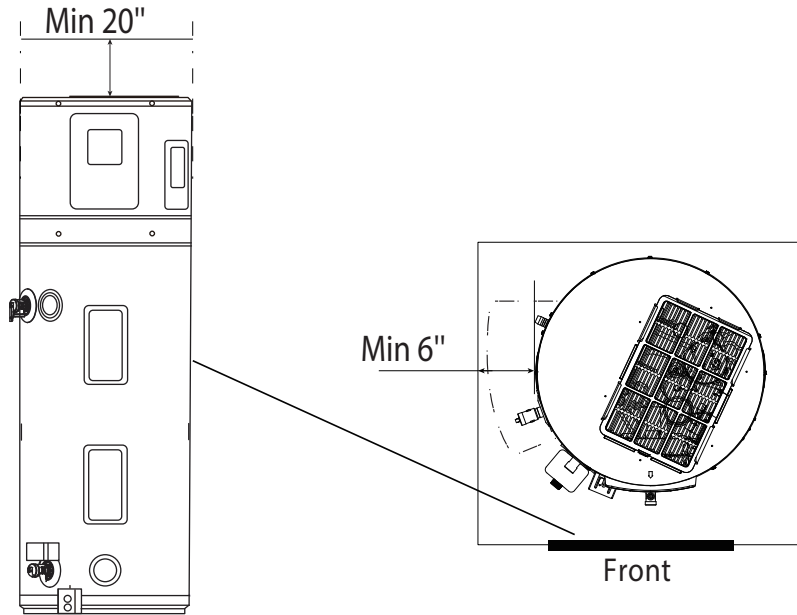

## Transport and Handling

### Positioning The Heat Pump

- Perform a Work Method Statements (WMS) or Job Site Analysis (JSA) on site to ensure safety. Be careful to unload all materials in a safe manner.
- For ease of unloading, position vehicle with all materials and the unit in a position near the work area.
- Installer **MUST** consider impact to living areas caused by noise of the water heater. Avoid positioning unit against wall shared with neighbors' bedrooms. The water heater is expected to run at night and noise caused by the unit (while low) can be considered interruptive to inhabitants of the home.
- **MAINTAIN** access to the relief valve and anodes.
- **OBSERVE** all plumbing and building regulations while installing unit. **ENSURE** the unit is installed on a flat and level surface.
- To prevent property damage from water spillage, you **MUST** use a properly drained overflow tray (See AS/NZS 3500.4.2 for further details.)
- **DO NOT** drain into gardens or outdoor areas containing greenery.
- **DO NOT** start the job of installing the water heater when risks cannot be controlled.
- **ENSURE** 200m<sup>2</sup> of free space to provide clear ambient airflow around the water heater; this helps the water heater's performance. This free space must be clear of debris, stored items, tree branches, and obstructive elements.

#### NOTE

- **DO NOT** drain on to grass or garden beds.
- **DO NOT** commence a job where the risks cannot be controlled.
- Allow 200m<sup>3</sup> of free space surrounding the unit. This provides clear ambient air flow assisting the product's performance. Ensure the clearance requirements specified in the section 'Location' on page 9 are complied with. The area **MUST** also be clear of debris such as leaves and tree branches.

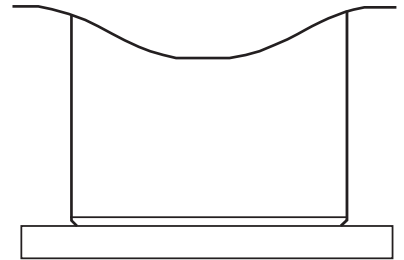

Install a plinth under the heat pump where it is subjected to wet conditions

## Thermal Expansion

An open water system occurs if a cold water inlet line does not have a check valve or back flow prevention device. This can cause a problem when thermal expansion occurs. Thermal expansion is the increase in pressure and volume that water undergoes when it is heated. In an open water system, this thermal expansion of the water exceeds the capacity of the water heater and then flows back into the city main where the pressure is easily dissipated.

In contrast, a closed water system prevents the expanding water from flowing back into the main supply line. This can create a rapid and dangerous pressure increase in the water heater and system piping, which will activate the safety setting of the relief valve. When the relief valve is constantly activated, it will cause premature failure. Please note that replacing the relief valve WILL NOT resolve the problem.

**To control thermal expansion, please install an expansion tank in the cold water line between the water heater and the check valve.** The expansion tank relieves the over pressure condition and prevents the relief valve from being activated regularly. The expansion tank is built to have an air cushion built in that compresses as the system pressure increases.

If you require more information on this subject, please contact your installing contractor, water supplier or plumbing inspector. It is important to extend your water heater's longevity by using an expansion tank.

## Water Supply Connections

Refer to the illustration on Page 17 for water supply connections.

The HOT and COLD water connections use 3/4" NPT on all models. Please install a shut-off valve in the cold water line near the water heater. These appliances are intended to be permanently connected to the water mains, and shall not be connected by hose-sets. See page 15 for further instruction on "To Fill The Water Heater".

Water inlet or outlet pipes: The spec of the water inlet or outlet thread is 3/4" NPT (external thread). Pipes must be heat-resistant and durable. The outlet of drain pan should be connected to the drainage system by DETACHABLE HOSE -SETS. The new hose-sets supplied with the appliance are to be used and that old hose-sets should not be reused.

Installation of the pipe for PTR valve: The valve connecting thread is 3/4" NPT (internal thread). After installation, it must be confirmed that the drainpipe outlet is exposed in the air and all that piping is properly installed and free of leaks. Unit should be completely filled with water. Tempering valve should be installed per manufacturer's instructions. The water in this appliance does not need to be potable. If a potable water source is used for the equipment's water supply, the source water supply shall be protected against back siphonage by the equipment.

The water inlet or outlet of the equipment is unpotable. A one-way valve must be installed on the water inlet side, as well as an isolation valve. It is normal for some water to be released from the PTR valve during operation. If there is a large volume of water, call your service agent for instructions. After long term use, check the unit base and fittings.

If damaged, the unit may sink, resulting in injury. Arrange the drain pipe to ensure smooth draining. Improper drainage work may cause wetting of the building, furniture, etc. Do not touch the inner parts of the controller or remove the front panel. Some parts inside are dangerous to touch, and damage may be caused.

## NOTICE

**DO NOT** apply heat or heating processed to the **HOT** or **COLD** water connections during installation; doing so will damage the heat traps. Connect the hose to the adapter before installing the adapter to the water connection on the heater.

## Condensate Drains

Consult local codes or ordinances for specific requirements. Refer to page 9.

**IMPORTANT:** When making drain fitting connections to the drain tubing, use secure clamps.

**IMPORTANT:** When making drain fitting connections to the drain tubing, **DO NOT** over tighten. Over tightening fittings can split pipe connections on the drain pan.

- For more requirements, please consult local codes or ordinances. Refer to page 9.
- **IMPORTANT: USE SECURE CLAMPS** when making drain fitting connections to the drain tubing.
- **IMPORTANT: DO NOT** over-tighten when making drain fitting connections to the drain tubing. Over tightening fittings can split pipe connections on the drain pan.
- **DO NOT** reduce drain line size less than connection size provided for the condensate drain.
- To ensure proper drainage, pitch drain lines downward away from the unit a minimum of 1/8" per foot of line. Include a P-trap in drain line if it is connected to a sewer pipe.
- **DO NOT** allow water heater drain pan to be used as a condensate drain.
- **INSULATE** the drain line to prevent sweating and damage due to condensate forming on the outside surface of the line.

## NOTICE

Condensate is not required to be neutralized from this unit because it is not acidic.

## Typical Installation

A temperature and pressure relief valve (that complies with the Standard for Relief Valves for Hot Water Supply Systems, ANSI Z21.22) is factory installed and must remain installed.

**DO NOT** install a valve of any type between the relief valve and the tank.

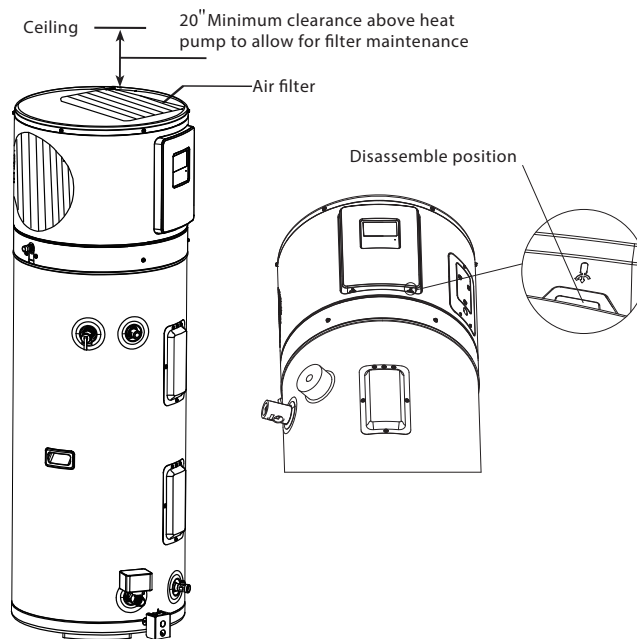

## Relief Valve (T&P Valve)

Look at the rating label of the water heater. The btu/h rating of the relief valve must not be less than the input rating listed (1 watt = 3.412 btu/h).

**DO NOT** allow discharge water to contact live electrical parts. Make sure that the relief valve is connected to a suitable open drain.

**ONLY** use piping that is approved for hot water distribution. The outlet of the valve must pitch downward from the valve. This allows complete drainage (by gravity) of the relief valve and discharge line. The discharge line should be protected from freezing.

**DO NOT** install a valve of any type, restriction or reducer coupling in the discharge line.

### CAUTION

To reduce the risk of excessive pressures and temperatures in this water heater, install temperature and pressure protective equipment required by local codes and no less than a combination temperature and pressure relief valve certified by a nationally recognized testing laboratory that maintains periodic inspection of production of listed equipment or materials, as meeting the requirements for Relief Valves and Automatic Gas Shutoff Devices for Hot Water Supply Systems, ANSI Z21.22. This valve must be marked with a maximum set pressure not to exceed the marked maximum working pressure of the water heater. Install the valve into an opening provided and marked for this purpose in the water heater, and orient it or provide tubing so that any discharge from the valve exits only within 6 inches above, or at any distance below, the structural floor, and does not contact any live electrical part. The discharge opening must not be blocked or reduced in size under any circumstances.

### WARNING

The pressure rating of the relief valve must **NOT** exceed the maximum working pressure of the water heater as marked on the rating place (150 PSI).

### WARNING

**T&P plumbing MUST** go directly to a suitable open drain.  
**T&P MUST NOT** connect to the condensate plumbing.

## To Fill the Water Heater

Ensure the closure of the drain valve before starting this process. For the cold water supply line, open completely. Allow the air to vent from the water heater and piping by opening each hot water faucet slowly to allow. A steady flow of water from the hot water faucet(s) indicates a full water heater.

## WARNING

**ENSURE the water heater is completely filled with water before turning on the electrical supply. If the water heater is operated with an empty or partially empty tank, the warranty does not cover the resulting damage or failure.**

## WARNING

The manufacturer's warranty will be void if installer or owner fails to follow the instructions provided in this manual. Failure to follow directions in this manual may permanently damage the unit.

Right Side View

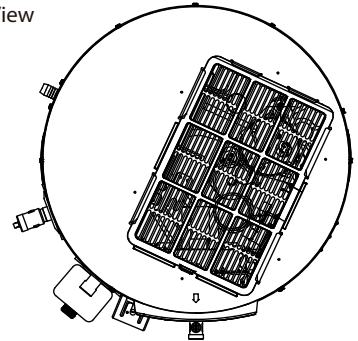

## Electrical Connections

### WARNING

Before making any electrical connections, turn off electric power at the fuse box or service panel. ENSURE ground connection is completed before making line voltage connections. Death, injury, or electrical shock can result in failure to do so. Also, before any maintenance, disconnect all power to unit before starting maintenance. DO NOT operate the water heater if the water heater has been subjected to fire, flood or physical damage, until it has been checked by a qualified service technician.

A qualified electrician must be commissioned to provide a separate branch circuit with copper conductors, over current protective device and suitable disconnecting, Latest edition of National Electrical Code ANSI/NFPA 70 and all local codes must be conformed to for wiring.

The water heater must be completely wired to the junction box inside jacket at the top front of the water heater. There is an opening for a 1/2 in. or 3/4 in. electrical fitting for wiring connections.

### Water Heater Junction Box

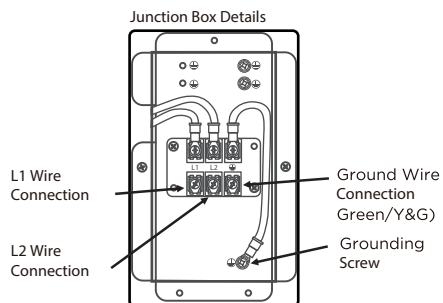
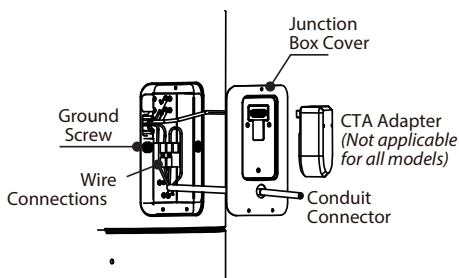

### NOTICE

If this water heater or any part of this water heater has been under water and/or flooded, DO NOT attempt to repair the unit! It must be replaced.

## Grounding Instruction

1. Metallic conduit or metallic sheathed cable (approved for use as a grounding conductor) must be installed with fittings approved for the purpose.
2. A separate conductor for grounding shall be included for non-metallic sheathed cable, metallic conduit or metallic sheathed cable not approved for use as a ground conductor.
3. The unit must be installed with a circuit breaker (including GFCI type) near the power supply and must be properly grounded.
4. Refer to page 39 for all wire connections.

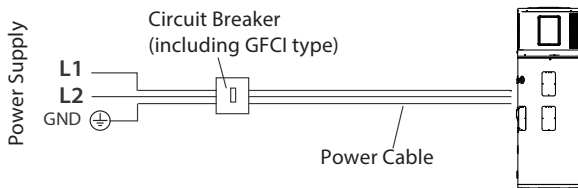

### NOTICE

Refer to National Electric Code. Refer to wiring diagrams in this manual for field wiring connections.

## Branch Circuit Sizing And Wire Size Guide - Single Phase Wiring

Maximum Wattage	Recommended Over Current Protection (Fuse or Circuit Breaker Amperage Rating)		Copper Wire Size AWG Based on N.E.C Table 310-16 167°F(75°C)
	208V	240V	240V
5500	25	30	10

**NOTE:** When sizing the breaker and wire for over current protection, include an additional 500W to the upper element wattage rating for the maximum amperage draw of the compressor and fan motor.

### WARNING

**MAKE SURE** unit is full of water before turning on the electrical supply or operating this water heater.

### CAUTION

Note that the presence of water in the piping and water heater does not provide acceptable conduction for a ground. The water heater can become electrically isolated if non-metallic piping, dielectric unions, flexible connectors, etc. are used.

## Insulation Blankets

### WARNING

Follow the manufacturer's instructions on insulation blanket kits included with the kit carefully if local codes require external application of insulation blanket. An insulation blanket can reduce standby heat loss. This manufacturer's warranty does not claim responsibility for any damage or defect caused by installation, attachment or use of any type of energy saving or other unapproved devices (other than those authorized by the manufacturer) into, onto or in conjunction with the water heater.

### CAUTION

If local codes require the application of an external insulation blanket to this water heater, pay careful attention to the following so as not to restrict the proper function and operation of the water heater:

- Operating or warning labels attached to the water heater **MUST STAY** visible.
- Air openings on both sides of the water heater **MUST STAY OPEN**.
- Controller Assembly, temperature and pressure relief valve or drain valve **SHOULD NOT** be covered.
- Frequently inspect the insulation blanket.

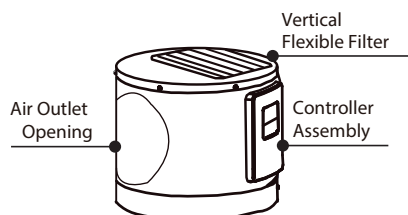

## Hot and Cold Pipe Insulation Installation

Install the insulation on the cold water supply inlet and the hot water outlet as shown in the illustration.

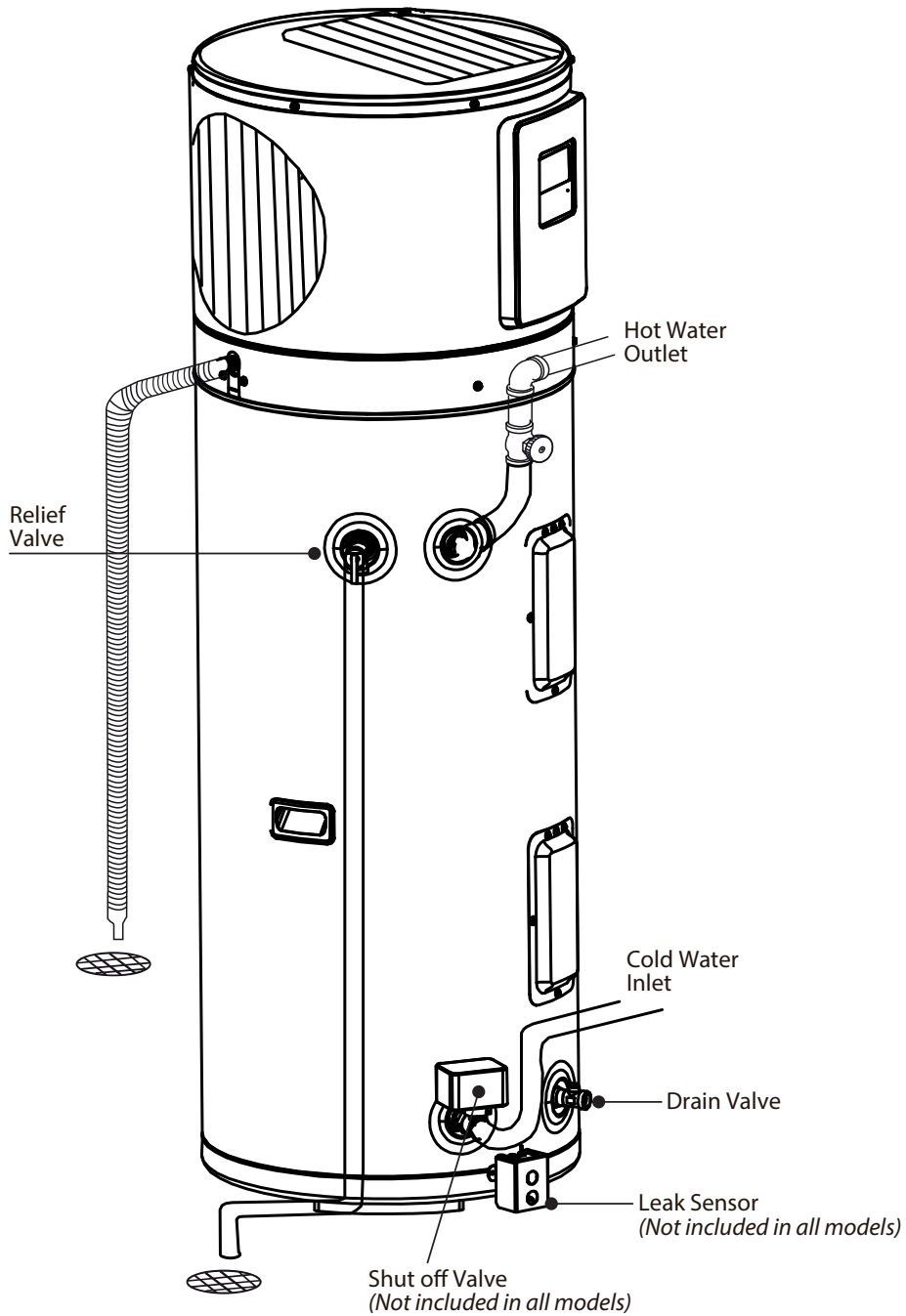

# OPERATING INSTRUCTIONS

## Operating The Water Heater

### CAUTION

Hydrogen gas (EXTREMELY FLAMMABLE) can be produced in a hot water system served by this water heater that has not been used for a period of two weeks or more. It is recommended that the hot water faucet be opened for several minutes at the kitchen sink before using any electrical appliance connected to the hot water system.

You will hear a strange sound of air escaping if hydrogen is present. Do not have open flame or smoke near any facet if this is the case.

### Safety Precautions

1. If water heater has been subjected to overheating, fire, flood, or physical damage, disconnect the power.
2. Fill water heater completely before turning on the water heater.
3. If cold water supply shut-off valve is closed, DO NOT turn on the water heater.
4. It is recommended that a qualified person or serviceman perform the work.

### WARNING

If the water heater has been subjected to fire, flood or physical damage, disconnect all power to water heater. DO NOT operate the water heater again until it has been checked by a qualified service technician.

### NOTICE

**DO NOT** use this appliance if any part has been under water. Immediately call a qualified installer or service agency to replace a flooded water heater.

**DO NOT** attempt to repair the unit! It must be replaced.

### Safety Controls

The water heater is equipped with a temperature limiting control (ECO) that is located above the upper heating element in contact with the tank surface. If for any reason the water temperature becomes excessively high, the temperature limiting control (ECO) breaks the power circuit to the heating element. Once the control opens, it must be reset manually.

### Resetting ECO

**The cause of the high temperature condition must be investigated by a qualified service technician and corrective action must be taken before placing the water heater in service again.**

To reset the temperature limiting control (Refer to illustration in Cavity Insert section):

1. Disconnect all power to unit before starting maintenance.
2. Remove the upper cavity cover and insulation.
3. Press the red RESET button.
4. Replace the insulation, jacket access panel and plastic housing before turning on the power to the water heater.

## Operating The Water Heater (cont.)

### **DANGER**

There is a hot water scald potential if the thermostat is set too high. Households with small children, disabled, or elderly persons may require a 120°F (49°C) or lower thermostat setting to prevent contact with **HOT** water.

### Water Temperature Setting

The temperature of the water in the water heater can be regulated by selecting the desired temperature on control display. Safety and energy conservation are factors to be considered when selecting the water temperature setting of the water heater. The lower the temperature setting, the greater the savings in energy and operating costs.

To comply with safety regulations the temperature is factory set at 120°F (49°C) (For CNU -factory set to 140°F (60.0°C) or less where local codes require. This is the recommended starting point. Severe burns can occur from hot water.

Be sure to read and follow the warnings outlined in this manual and on the label on the water heater.

This label is located on the front of the water heater.

Mixing valves are recommended for reducing point of use water temperature by mixing hot and cold water in branch water lines. It is recommended that a mixing valve complying with the Standard for Temperature Actuated Mixing Valves for Hot Water Distribution Systems, ASSE 1017 be installed. See page 4 for more details and contact a licensed plumber or the local plumbing authority for further information.

When used in demand response applications a thermostatic mixing valve conforming to ASSE 1017 shall be installed on the hot water supply line following all manufacturer installation instructions. See page 32 for additional installation information.

The chart on the page 4 may be used as a guide in determining the proper water temperature for your home.

## Local Startup (cont.)

### Change Mode of Operation

Press the "MODE" button to select operating mode.

#### Operation Modes

- Vacation
- Hybrid
- E-Heater
- Economy
- Heat-Pump

Mode	Efficiency	Recovery
Vacation	N/A	N/A
Hybrid	Low	Very High
E-Heater	Very Low	High
Economy	High	Low
Heat-Pump	Very High	Very Low

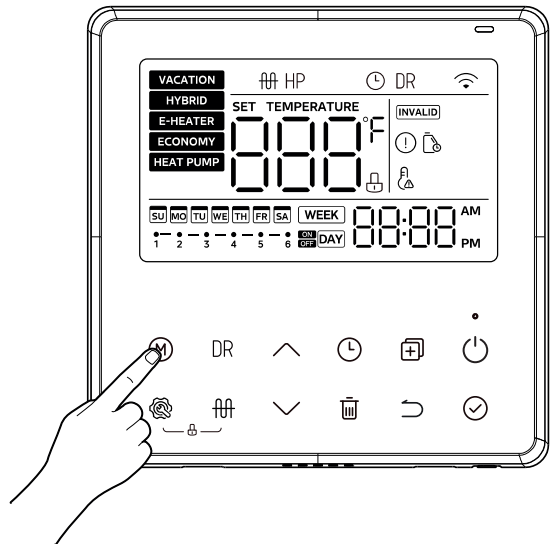

### Setting Menu

Enter the engineering channel mode:

Long press and hold the check button for 3 seconds on the main interface.

Select engineering channel, press the confirm button to enter, and switch between valid values using the up/down keys.

#### Engineering channel

Engineering channel 1	Temperature unit switching	0-Centigrade 1-Fahrenheit degree
Engineering channel 2	Maintenance reminder on	0 : Off 1: On
Engineering channel 3	Maintenance time setting	Default value : 365 days
Engineering channel 4	Zero maintenance time	0 : Do not clear ; 1: Clean up
Engineering channel 19	E-Heater mode automatically switches to Economy mode	0: No 1:Yes
Engineering channel 20	Hybrid mode automatically switches to Economy mode	0: No 1:Yes
Engineering channel 30	Backlight	0 : O ff(Backlight always on) 1: O n(Normal mode)
Engineering channel 34	Turn off sound	0 : Off (Normal mode) 1: On(No buzzer sounds)

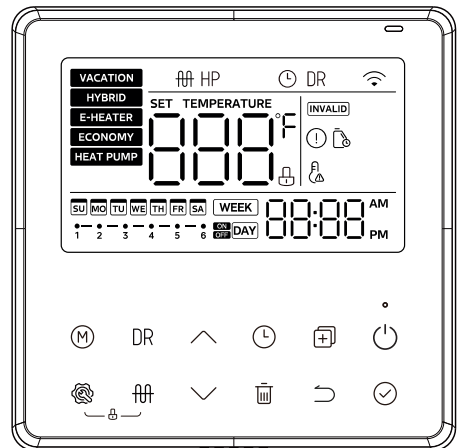

Engineering channel 35	Automatic child lock	0 : Off (Normal mode) 1: On
Engineering channel 38	Ball Valve	0 : Null 1: With
Engineering channel 39	Forced sterilization	0 : Off 1: On(Valid once)
Engineering channel 40	Air duct	0 : Null 1: With 2: Not recommended to set

# CARE & CLEANING

## Draining the Water Heater

### CAUTION

Be sure to shut-off power to the water heater before attempting to drain the water heater.

### DANGER

Before manually operating the relief valve make certain no one will be exposed to the hot water released by the valve to avoid any scald risk, injury or damage.

Do not use volatile oils, alcohols, thinners, lacquers, etc. to clean the machine; otherwise, the product may be damaged.

Turn off the cold water supply before draining the water heater.

Attach a garden hose to the drain valve on the water heater, open the T&P valve, and direct the stream of water to a drain. Open the valve.

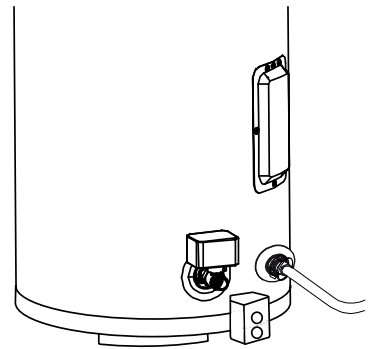

## Routine Preventative Maintenance

Your water heater will provide years of dependable trouble free service if you maintain your water heater properly. However, contact a qualified installer or plumbing contractor to inspect unit if you see or hear any strange behavior.

Annually you must:

1. Lift and release the lever handle on the temperature pressure relief valve and allow water to discharge from the system.
2. Clean the air filter (or more often as needed). A clean filter is important for keeping air flow to heat pump from being obstructed.
3. Pour bleach down the condensate drain.
4. Check that the condensate can flow freely.
5. Drain water heater to clear debris accumulated in tank from hard water deposits.

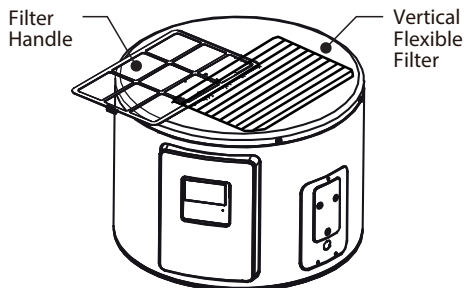

## Vacation and Extended Shut-Down

### NOTICE

Refer to the Hydrogen Gas Caution in the Operating Instructions.

The power and water to the appliance should be turned off to conserve energy and prevent a build-up of dangerous hydrogen gas for periods of inactivity longer than 2 weeks.

If there is risk that the water heater and piping will be subject to freezing while the unit is inactive, the water heater and piping should be drained.

The water heater's operation and controls should be checked by a qualified service person after a long shut-down period. Make sure to completely refill the water heater before placing it in operation.

## Anode Rod

### NOTICE

The life of the glass-lined tank can be prolonged by the anode rod as it prevents corrosion of the tank.

The gas-lined tank of this water heater is protected by an anode rod. The purpose of this rod is to attract corrosive elements inside of hard water so that the anode rod is sacrificed to corrosion instead of the inside of the water heater. For cases where the water contains high mineral content or high sulfates, this process of the anode rod reacting to the water can cause an odor. This odor is similar to rotten eggs. This can happen especially during long periods of inactivity. In this case, the owner can use the chlorine bleach removal method by adding an automatic chlorination to the water system. The chlorine will eliminate the rotten egg smell because it chemically reacts with hydrogen sulfide and disinfects the water.

# TROUBLESHOOTING TIPS

## Before You Call For Service

 Save time and money! Review the chart on this page first and you may not need to call for service.

## Troubleshooting

### 1 Non-error tips

Q: Why won't the compressor start immediately after turning on the unit?

A: The pressure of the system needs to be balanced. This is a self-protection logic of the unit that should take 3-4 min.

Q: Sometimes the temperature shown on the display panel decreases while the unit is running, why is this?

A: The upper tank temperature and bottom tank temperature will mix when there is a temperature difference, thus lowering the reading. This is not an abnormal operation.





Q: The display shows decreased temperature unit but the unit is closed?

A: To avoid cutting on and off repeatedly, the machine will turn on only when T5U temperature is lower than setting temperature for at least 41 °F/5°C(50 Gal)/ 39.2°F/4°C(80 Gal).

Q: Why does the temperature shown on the display sometimes decrease but I still have hot water?

A: The upper water sensor is positioned on the upper 1/4 of the water heater and therefore there is still about 1/4 of the tank of hot water available to the user.

Q: Why is it that sometimes the buttons are unavailable?



A: The panel may be locked, press the " " and " " for 2 seconds, the unit will lock the panel, shows " ", to unlock the panel, please press the " " and " " for 2 seconds again.

Q: Sometimes there is some water that flows from the drainage pipe of the PT valve, why does this occur?

A: Because the tank is pressure-bearing, when water is heated inside the tank, water will expand, so the pressure inside the tank will increase. If the pressure goes up more than 1.0MPa, the PT valve will activate to relieve the pressure and hot water drop will be discharged correspondingly. If water drop is continually discharged from the PT valve drainage pipe, it is abnormal. Please contact qualified staff to check.

### 2 Self-protection of unit

1. When self-protection happens, the system will be stopped and start self-check, and restart when the protection is resolved.

2. When self-protection happens, the buzzer will buzz in every other minute, the " " light will light up and error code will be shown at the water temperature indicator. The " " and error code does not disappear until protection is resolved.

3. In the following circumstances, self-protection may happen;

- Air inlet or outlet is blocked;
- The evaporator is covered with too much dust;
- Incorrect power supply (exceeding the range of 187-265V).

### 3 Recognizing an Error

1. If some normal errors happen, please contact qualified staff to repair.

2. If some severe errors happen, the unit will not start. Please contact qualified staff to repair.

3. If a fault occurs, the " " icon will light up, the buzzer will beep and the main interface will display a fault code.

## Troubleshooting (cont.)

### 4 Error phenomenon shooting

Error Phenomenon	Possible Reason	Solution
Cold water tapped out and display screen extinguished	<ol style="list-style-type: none"><li>1. Bad connection between power supply plug and socket;</li><li>2. Setting water temperature too low;</li><li>3. Temp. sensor broken; PCB of indicator broken.</li></ol>	<ol style="list-style-type: none"><li>1. Plug in;</li><li>2. Setting water temp. higher;</li><li>3. Contact service center.</li></ol>
No hot water tapped out	<ol style="list-style-type: none"><li>1. Public water supply ceased;</li><li>2. Cold water inlet pressure too low (&lt;0.15 MPa);</li><li>3. Cold water inlet valve closed.</li></ol>	<ol style="list-style-type: none"><li>1. Waiting for public water supply recover;</li><li>2. Waiting for inlet water pressure increase;</li><li>3. Open water inlet valve.</li></ol>
Water leakage	Hydraulic pipeline joints are not sealed well.	Check and reseal all joints.

# 1 Basic function

## 1. Vacation function

Press “**M**” the button to select VACATION, unit will automatically heat water to 59°F (15°C) for the purpose of energy saving during vacation days.

## 2. How is the unit running

If unit is OFF - > press “**⏻**” - > unit will be awoken > press “**^**” to set target water temperature (109°F/43°C~149°F/65°C) -> press “**⏻**”->unit will automatically select heat source and start to heat water to target temperature.

## 3. Remote shutdown function

Users can connect a switch. If the switch is closed, the unit will be stopped forcibly. If switch breaks, the unit can run normally according to settings.

# 2 Query function

Press the “**🌀**” button then system running parameters will be shown one by one with following sequence by each pushing of “**^**” or “**∨**” button.

No.	Hour low bit	Min. high bit	Min. Low bit	Unit	Explanation
1	T	S	U	Temp.	TSU
2	T	S	L	Temp.	TSL
3	T	S	I	Temp.	---
4		T	S	Temp.	Heat pump stop temp
5		T	3	Temp.	T3
6		T	4	Temp.	T4
7		T	P	Temp.	TP
8		T	H	Temp.	Th
9		o	n		---
10	T	F	r		---
11		T	T	Temp.	Disinfect temp.
12		ℓ	o	Current	Compressor and electric heating current

No.	Hour low bit	Min. high bit	Min. Low bit	Unit	Explanation
13		F	o	Fan	Ac Fan 0: OFF 1: LOW 2: MID 3: HIGH Dc Fan Real speed/10
14		E	o	Machine parameters	0~255
15	E	E	r		Electronic expansion valve opening
16	E	E	ℓ		Compression mechanism hot water demand
17	P	U	P		---
18		P	S		---
19		F	T		0: Ac Fan 1: Dc Fan
20		H	T		1(E-Heater control type)
21		H	P		0(Compressor control type)
22	F	S	I		---
23	S	I	o		Tank capacity
24	P	4	P		Four-way valve status
25		U	U		0
26		U	I	Version	Host software version
27		U	2	Version	LCD panel software version
28		U	3	Version	000
29		U	4		0: One electric heater 1: Two electric heaters
30		U	T		2
31	I	E	r		Last error code
32	2	E	r		Previous 1st error or protection code
33	3	E	r		Previous 2nd error or protection code
34	H	H	H		Maintenance time
35	T	L	F		Target Temp
36	E	n	d		End sign

# 1 Operation

## 1.1 Control Panel Explanation

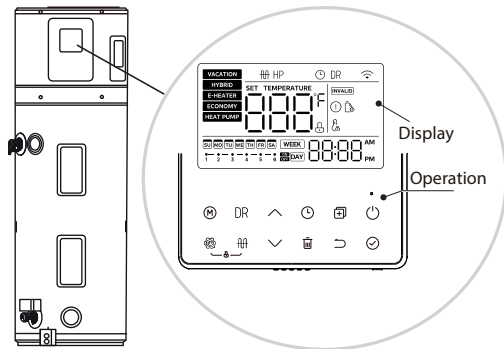

## 1.2 Display Explanation

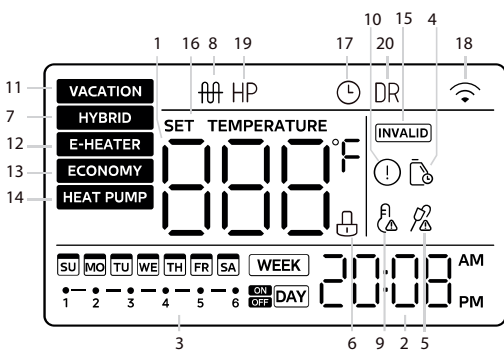



N0	Icon	Description
①	888°F	888 will be displayed if screen is unlocked. It shows water temperature on normal; It shows remaining vacation days on vacation; It shows setting temperature on setting; It shows unit setting/running parameters, error/protection code on querying.
②	20:08	<b>TIME AND CLOCK SETTING</b> 20:08 shows the clock. Whenever there is any setting for clock, SET TIME will be displayed.
③	WEEK ON/OFF DAY	There are daily or weekly TIMER icons. If any one of them has been set, this icon will display the corresponding one when screen is unlocked. If none of timers has been set, it will stay off.  If timer has been set, this icon will flash the corresponding one with 2Hz frequency as well as display the timer that has been set..
④	Maintenance reminder icon	This will flash to remind the user to maintain the water tank and clean the air filter. If you do not need maintenance reminders, you can enter engineering mode channel 2 to disable this function, or engineering mode channel 4 to reset the maintenance reminder time. The default maintenance reminder time is 365 days.
⑤	Electronic magnesium rod reminder icon	<b>ELECTRONIC MAGNESIUM ROD REMINDER:</b> This will be displayed when the electronic magnesium rod reaches the end of its service life. (some units)
⑥	Lock icon	<b>LOCK:</b> Icon will be displayed if button is locked, otherwise it will remain off.
⑦	HYBRID	<b>HYBRID MODE:</b> The heat pump and the electric heater are running at the same time.
⑧	E-HEAT icon	<b>E-HEAT:</b> This icon will be displayed when E-Heat is running, otherwise it will remain off. NOTE: When the operating conditions are not met to turn on this function, the corresponding icon on the wire controller lights up briefly and then goes out.
⑨	High Temp. Alarm icon	<b>HIGH TEMP. ALARM</b> If water temp is higher than 122 °F (50°C), the icon will be displayed, otherwise it will remain off.
⑩	ERROR icon	<b>ERROR:</b> It will be lightened when unit is under protection/error.
⑪	VACATION	<b>VACATION MODE:</b> For the outgoing vacation mode, the water tank is set at 59 °F (15°C). This maintains low tank water temperature, preheats hot water and anti-freeze lines, while reducing on/off operation of the tank.



N0	Icon	Description
12		<b>E-HEATER MODE:</b> This icon will be displayed when the appliance is running in E-HEATER MODE. In this mode, only the heating element will work (won't work at the same time).
13		<b>ECONOMY MODE:</b> This icon will be displayed when the appliance is running in ECONOMY MODE. In this mode while the ambient temperature is at the heat pump ambient operating range, heat pump will work if T5U/T5L is lower than special parameter. Upper upper heating element will work when T5U is lower than 36 C. If the ambient temperature is out of the heat pump ambient operating range, only the heating element will work (won't work at the same time).
14		<b>HEAT PUMP MODE:</b> This icon will be displayed when the appliance is running in HEAT PUMP MODE. In this mode while the ambient temperature is at the heat pump ambient operating range, the heat pump will work if T5U/T5L is lower than special parameter. If the ambient temperature is out of the heat pump ambient operating range, only the heating element will work (won't work at the same time).
15	INVALID	When any key is invalid, this icon will flash 3 sec.
16	SET TEMP	The icon lights up when the water temperature is being set.
17		The icon lights up when the clock is being set.
18		<b>WIRELESS:</b> (some units) will be displayed when Wireless is connected; will be off when Wireless is not connected; will flash with 2Hz frequency when setting Wireless.
19	HP	<b>HEAT PUMP ICON:</b> When the heat pump is operating and producing hot water, the icon lights up.
20	DR	<b>DR ICON:</b> After the DR function is enabled, if general curtailment, basic load up, advanced load up, or critical curtailment request is received, the icon DR will flash slowly; when receiving the grid emergency request, the icon DR will flash quickly.







Pressing any button is effective only under button and display unlocked state.

Icon	Description
	Use this key to switch mode
	Default ECONOMY mode
	Switch to HEAT PUMP mode
	Switch to VACATION mode
	Adjust vacation days (1-360 days)
	Switch to HYBRID mode
	Switch to E-heater mode
	Switch to ECONOMY mode
	If no user changes the device mode within 72 hours, it will automatically switch to ECONOMY mode (72 hours is the power on time)
	DR button is valid once.
	When the DR icon goes out, the DR function is not turned on. Click this button to turn on the DR function. After waiting for it to turn on, the DR icon stays on.
	After the DR function is enabled, if general curtailment, basic load up, advanced load up, or critical curtailment request is received, the icon DR will flash slowly; when receiving the grid emergency request, the icon DR will flash quickly
	To turn off the DR function, click the DR button again while the DR is on and the device is on. The DR icon will turn off.

NO	Icon	Description
③		<p>INCREASE AND DECREASE</p> <p>If screen is unlocked, corresponding value will increase by pressing the button.</p> <ul style="list-style-type: none"> <li>• <b>When setting temperature, press for more than 1s,</b> temperature value will be increased continuously;</li> <li>• <b>When setting clock/timer, press for more than 1s,</b> clock/timer value will be increased continuously;</li> <li>• <b>When setting vacation days, press for more than 1s,</b> day value will be increased continuously;</li> </ul> <p>On querying, check items will page up by pressing it.</p>
④		<p>QUERY FUNCTION</p> <p>1) In the main interface, press the search to enter the spot check function, and use the up and down keys to switch the spot check channel. The attribute value of the channel will be displayed when switching to the channel. The specific channel can be found in the function book.</p> <p>2) After 30 seconds from the last operation of the up and down keys, or by pressing the return key or the on/off key, you can directly exit the engineering mode;</p> <p>3) Query mode can be entered in both power-on and power-off state.</p> <p>ENGINEERING MODE</p> <p>1) In the main interface, press and hold the key for 3 seconds to enter the engineering mode; use the up and down keys to switch the inspection channel, and the attribute value of the channel will be displayed when switching to the channel. Using the up and down keys, you can modify a parameter setting. After setting and adjusting, press confirm key to return to the main interface to make the setting effective (channel 2, 3, 4, 34, 35 will be effective immediately). Press the Return button to return to the previous interface (channel selection interface). After 30 seconds from the last operation of the up and down buttons, or by pressing the return button or the on/off button, you can directly exit the engineering mode.</p> <p>2) Engineering mode can be accessed in both power-on and power-off state.</p> <p>It is strictly prohibited for the customer to change the parameter settings of other channels in the engineering mode without authorization to avoid affecting the normal operation of the unit or causing damage to the prototype.</p>
⑤		<p>POWER ON/OFF BUTTON</p> <p>Press the button to turn the device on or off.</p>

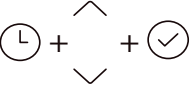
NO	Icon	Description
⑥		<p>TIMER (Daily setting)</p> <ol style="list-style-type: none"> <li>1) Press the TIMER (L) button to the day timer icon (DAY), press the confirmation button (✓) to enter the day timer setting interface. The day timer has a total of 6 time periods; each time period can be set to open the time, close the time, mode, set the temperature of the water; when setting the first time period, set the temperature of the water, press the confirmation button to enter the next time period of the set; when setting the sixth time period, set the temperature of the water, press the confirmation button to return to the main interface; during this period, you can press the return button (↩) Return to the previous setting or main interface;</li> <li>2) When setting the on time and off time, press the delete button (⌫). The time can be restored to the default value, and displaying (-.-).</li> <li>3) If there is a conflict between the set time periods, the time period set at the back will be the valid time period, and the time period in front will be the invalid time period. The invalid time period restores the default setting.</li> <li>4) You can enter the daily timer setting in both power-on and power-off state.</li> </ol> <p>TIMER (Weekly setting)</p> <ol style="list-style-type: none"> <li>1) Press the TIMER button to the weekly timer icon (WEEK), press the confirmation button (✓) to enter the weekly timer setting interface. Weekly timer a total of 7 days. There are 6 time slots can be set each day. Each time slot can be set to open or close the time, mode, or set water temperature. After setting the water temperature for the first time slot, press the confirmation button to enter the next time slot settings; after setting the water temperature for the sixth time slot, press the confirmation button to return to weekly timer. After setting the water temperature for the 6th period, press the confirmation key to return to the selection of week; during this period, you can press the return key to return to the previous level of setting or the main interface.</li> <li>2) When setting the on time and off time, press the delete button (⌫) to restore the time, mode and set water temperature to the default value, and displaying (-.-).</li> <li>3) If you adjust the timer again after the setting is completed, then all the settings after the adjustment time period will be canceled. For example, if you adjust the timer on for time period 2, the timer off for time period 2, and the settings for time periods 3, 4, 5, and 6 will all be canceled to (-:---) after adjustment. Mode and setting water temperature become default values (Energy saving mode, 60°C(140 °F)).</li> <li>4) In the weekly timer setting, in the weekly selection use the copy button (⌘). You can locate the setting of a certain day to the base day, select other days, press the copy button to change the status of the day, the fast flashing is selected, the slow flashing is unselected, and after pressing on the confirmation button, you can copy the setting of the base day to the selected day;</li> <li>5) You can enter the weekly timer setting in both power-on and power-off state.</li> </ol>
⑦		<p>CONFIRM/UNLOCK</p> <p>If screen and buttons are unlocked, press it to upload setting parameters after setting any parameter.</p>

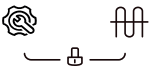
### 1.3 Combination button

No.	Icon	Description
Setting the date and clock		<p>1) In the main interface, press and hold the timer button for 3 seconds to enter the date setting. Press the up/down button to select the date, press the confirmation button to enter the clock setting, press the up/down button to modify the time, and press and hold to accelerate the increase/decrease of the time. After setting the clock, press the confirm button to return to the main interface to complete the setting of date and time.</p> <p>(2) After 30 seconds from the last operation of the up/down button or pressing the return button or the power on/off button, you can directly exit the date and time setting;</p> <p>3) Setting can be done in both power-on and power-off state.</p>
Connecting the wireless function	 <p>Press for 3 sec</p>	<p>1) In the main interface, long press the on/off key for 3 seconds to enter the AP wireless network mode. There will be a wireless icon in the upper right corner of the line controller. At this time, enter the APP, select the category of air water heater, choose the correct model, and then network according to the APP prompts, and after the network is completed, the wireless icon will be always on;</p> <p>(2) Wireless matching can last up to 8 minutes. After 8 minutes, if the matching is not successful, the wireless icon will go out;</p> <p>3) Long press the delete button for 8 seconds in the main interface to reset the wireless function;</p> <p>4) It can be set in both power on and power off state.</p>
Child lock function	 <p>Press for 2 sec</p>	<p>1) In the main interface, long press the key combination for 2 seconds to enter the child lock state;</p> <p>(2) In the state of child lock, long press the key combination again for 2 seconds to release the child lock state;</p> <p>3) In the locked state, there will be an icon  next to the water temperature display.</p>

Display	Malfunction Description	Corrective Action
EH0b	Tank and LCD panel communication error.	If connection between LCD panel and PCB has released or PCB has been broken.
EH00	Machine working parameters are abnormal.	Contact a qualified person to service the unit.
EH03	DC fan fault.	If connection between fan and PCB has released or fan has been broken. Contact a qualified person to service the unit.
PH15	Electric leakage error. If PCB current_induction_circuit check the current difference between L,N > 14mA, system consider it as "electric leakage error".	Some wires have been broken or if there is a bad wire connection, contact a qualified person to service the unit.
EC54	Compressor discharge temperature sensor TP error.	If connection between sensor and PCB has released or sensor has been broken contact a qualified person to service the unit.
EH5H	Compressor suction temperature sensor TH error.	
EC53	Ambient temperature sensor T4 error.	
EC52	Evaporator temperature sensor T3 error.	
EH5L	Error of sensor T5L (lower water temperature sensor).	
EH5U	Error of sensor T5U (upper water temperature sensor).	
EHLA	When the ambient temperature T4 is out of the compressor operating range, the compressor stops, and EHLA is displayed until T4 returns to the normal range. Only works on units without electric heaters. Devices with electric heaters will never display "EHLA".	It is normal, and not necessary to repair.
EH5d	Electric heater open-circuit error.	The electric heater has been broken or there is a bad wire connection after repair.
EHPH	Heat pump system fault. When PH20, PH21, PC30, PC06 any protection appears 3 times or the protection lasts 1 hour.	The compressor works abnormally. Contact a qualified person to service the unit.
PHdH	Dry burning protection.	Ensure that there is water in the water tank before heating.
PH20	Compressor abnormally stopped protection. The discharge temperature is not higher than evaporator temperature after compressor runs a term.	The compressor is broken or there is a bad connection between PCB and compressor. Contact a qualified person to service the unit.
PH21	The working current of the compressor is too large.	The compressor is broken, system is blocked, there is air, water or more refrigerant in the system (after repair), water temperature sensor malfunction, etc. Contact a qualified person to service the unit.
PH24	Frost protection. T5L < 39.2°F (4°C) and T4 < 44.6°F (7°C).	The cold water temperature is too low, which will affect the water tank. The electric heater will work.
PC30	System high pressure protection ≥ 3.0 MPa active; ≤ 2.4 MPa inactive	If the system is blocked, air or water or more refrigerant in system (after repair), water temperature sensor malfunction, etc. Contact a qualified person to service the unit.
PC06	High TP protection. Tp > 221°F (105°C). Protection active; Tp < 194°F (90°C) Protection inactive.	The system blocked, there is air, water or less refrigerant (leakage) in system (after repair), water temperature sensor malfunction, etc. Contact a qualified person to service the unit.
PH9b	Over temperature protection. The current water temperature exceeds the target temperature by more than 41°F (5°C).	The water temperature sensor is faulty or the current water temperature is too high. In case of burns, contact a qualified person to check.
PH91	Low T3 protection.	If the fault persists, contact a qualified person to service the unit.
PH22	Chassis leakage protection.	Check if the chassis is leaking water. If there is any leakage. Please clean and check the leakage port or contact after-sales personnel.
PHL1	Leakage protection of the water tray.	Check if the drain tray is leaking. If there is any leakage, please clean and check the leakage port or contact after-sales personnel.
FC06	Electric ball valve malfunction.	Check if the electric ball valve is working properly. If it does not work properly, please replace it or contact after-sales personnel.

# CUSTOMER SERVICE

## CTA Module Wiring

### Water Heater Junction Box

#### **WARNING**

A qualified technician must install a separate branch circuit with copper conductors and an over current protective device. They must also provide a suitable disconnecting means.

Please consult National Electrical Code ANSI/NFPA70 for wiring best practices.  
Please consult local codes.

1. Connect the Red wire of the water heater to Red wire of the CTA module box connection using an appropriately sized wire nut.
2. Connect the Black wire of the water heater to the Black wire of the CTA module box using an appropriately sized wire nut.
3. Connect the Green wire of the CTA module box to ground using the ground screws.
4. Locate the junction box in the water heater.  
It is at the top of the unit side of the upper jacket.

#### **NOTICE**

Look at the manufacturer instructions for the CTA2045 (that is ACTA2045 compliant) and install the module in the water heater's top connector.

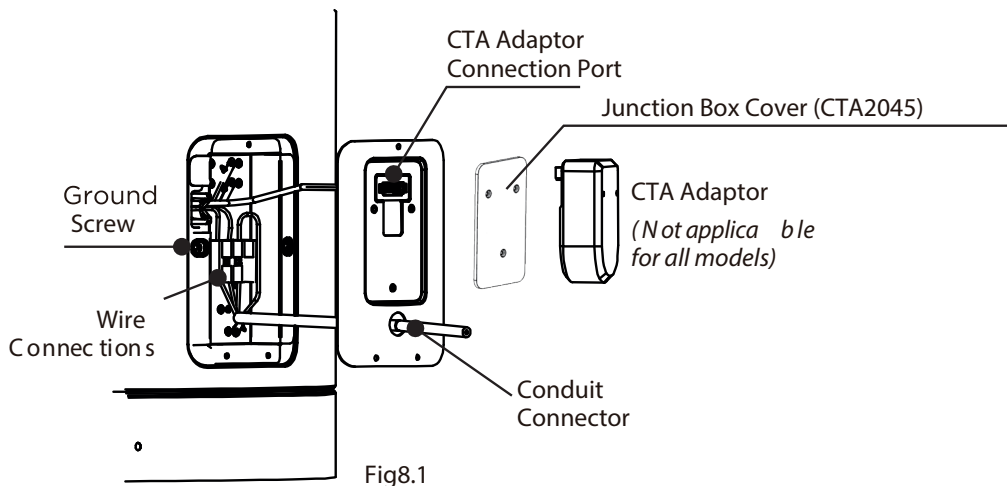

## Demand Response (CTA-2045) Installations

A thermostatic mixing valve conforming to ASSE 1017 shall be installed on the hot water supply line following all manufacturer installation instructions.

Maximum and minimum inlet water operating temperatures 48.2°F~107.6°F (9°C~42°C);

Maximum and minimum inlet water operating pressures 0.3 MPa-1.03 MPa and flow rate 0.2-0.7(m /h);

3

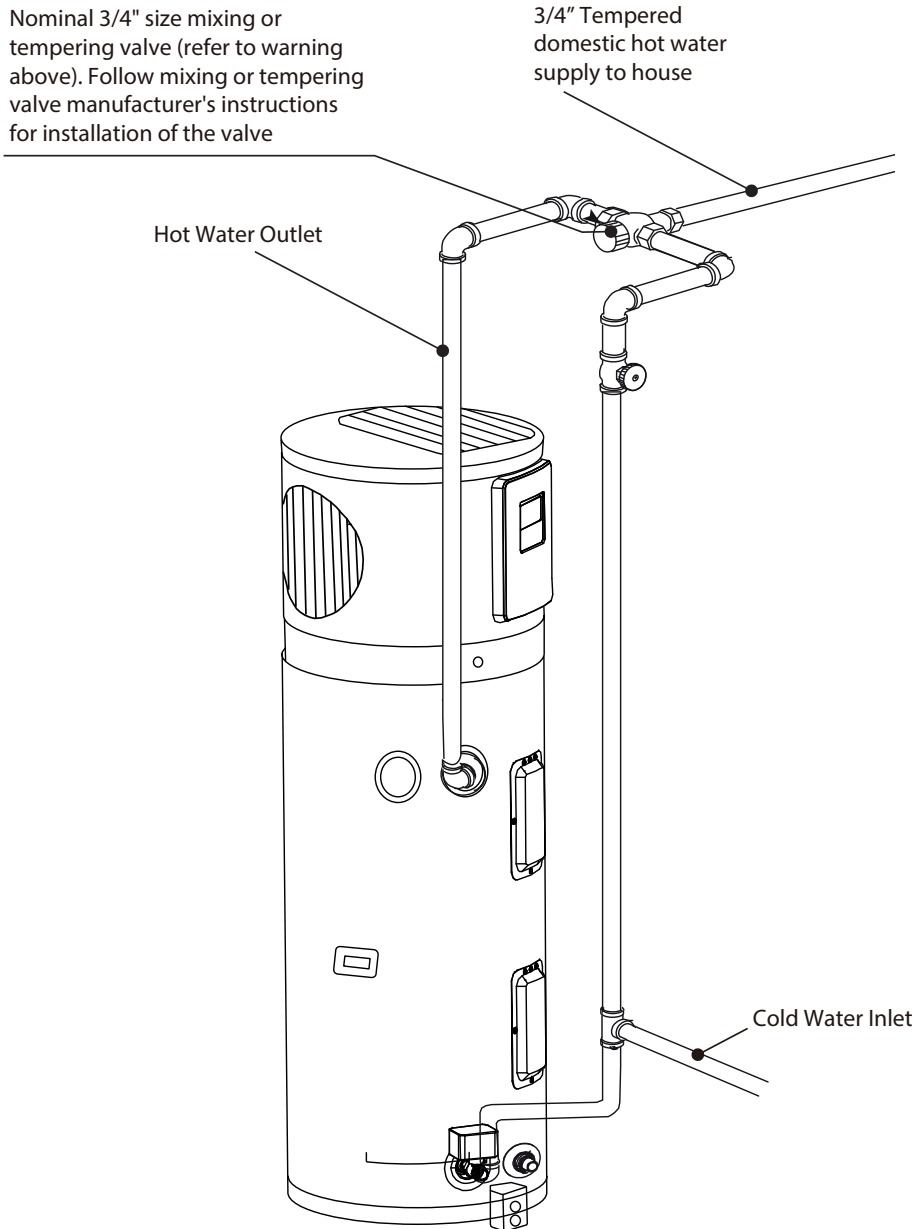

## Replacement Parts

### Instructions For Placing a Parts Order

Address parts orders to the distributor or store where the heater was purchased.

All parts orders should include:

1. The model and serial number of the water heater from the rating plate located on the tank jacket.
2. Specify voltage and wattage as marked on the rating plate.
3. Part description (as noted on [stream33.com](http://stream33.com)) and number of parts desired.

#### **NOTICE**

Check the water heater's rating label on the front of the unit for the acceptable element wattage.

#### **CAUTION**

For your safety **DO NOT** attempt repair of electrical wiring, heating elements, heat pump or electronic controls. Refer repairs to qualified service personnel.

#### **WARNING**

##### **FLAMMABLE CONTENTS UNDER PRESSURE.**

The compressor is not a serviceable part. The compressor wiring terminals may allow pressurized refrigerant and oil to escape, ignite and cause serious bodily injury, severe burns or death.

## Cavity Insert Instructions

### CAUTION

The following instructions are intended for qualified service personnel **ONLY**, and should only be done when necessary.

In order to replace the ECO, thermistor or heating element, remove the cavity insert crossbar by following the instructions below:

1. Disconnect all power to unit before to starting maintenance.
2. Remove the cap.
3. Replace the ECO, thermistor and/or element as necessary.
4. Recover the cap before turning on the power to the water heater.

### NOTICE

The cavity insert crossbar is necessary for the manufacturing process only.

The removal of the crossbar will not interfere with the operation of the water heater.

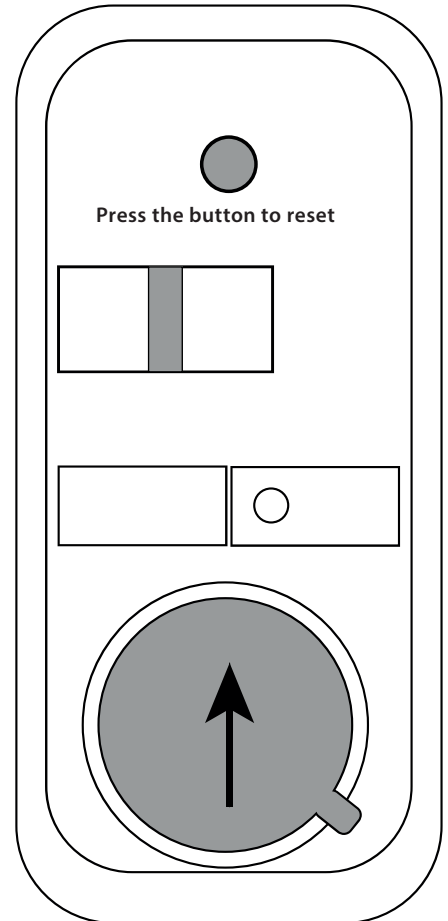

# Wiring Diagram

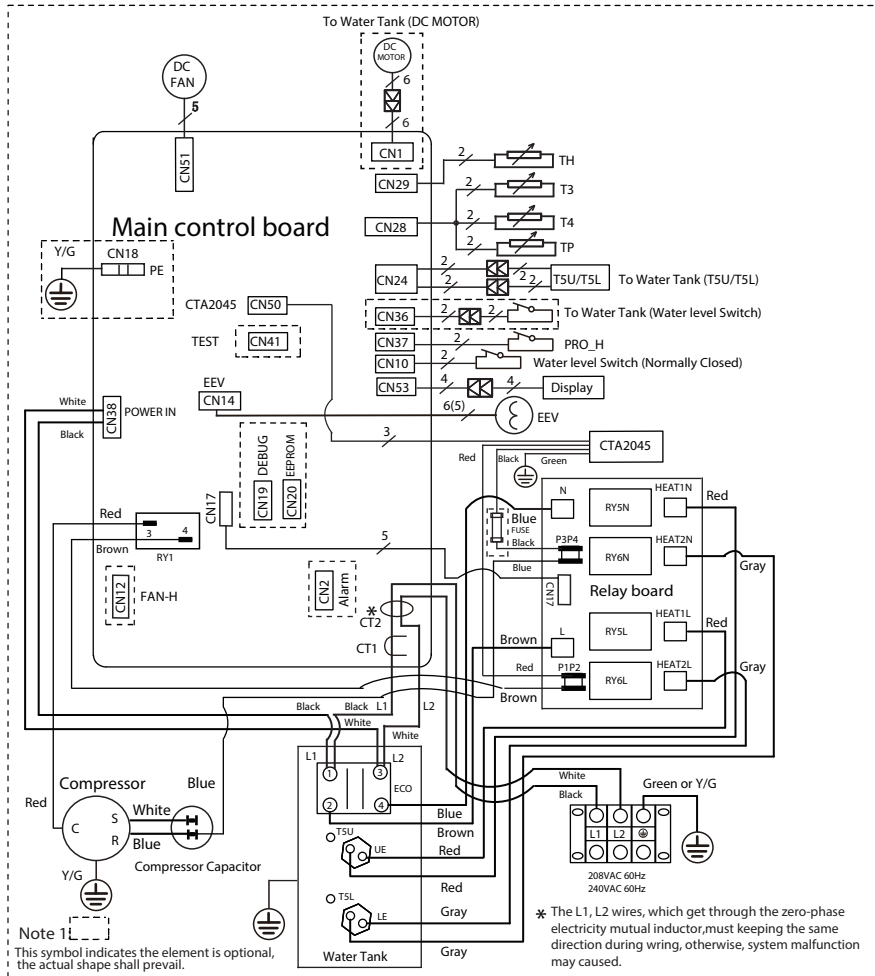

CT1	AC mutual inductor
CT2	Zero-phase electricity mutual inductor
T3	Evaporator temperature sensor
T4	Ambient temperature sensor
T5U	Tank temperature sensor (Upper)
T5L	Tank temperature sensor (Lower)
TP	Discharge temperature sensor
TH	Suction temperature sensor
EEV	Electric expansive value
ECO	Emergency cut off



#### **LIMITED WARRANTY**

Stream33 Products LLC (“Stream33”) warrants that this Heat Pump Water Heater tank and component parts (the “Product”) shall be free from defects in material, workmanship and/or manufacturing under normal use and service. This warranty applies to the original purchaser and all subsequent owners (“PURCHASER”) provided that the Product remains in the original installation location and was installed by a Licensed Contractor. Should your Stream33 Product prove to be defective in material, workmanship and/or manufacturing under normal use during the durations outlined below, within the earlier of (i) sixty (60) days following date the equipment is first installed by a licensed contractor or (ii) from three (3) months or 90 days after the date of distribution from Stream33 (without proof of installation date), Stream33 will replace defective parts or Product as outlined below. All warranty parts, product and labor claims are subject to Stream33 inspection of the product and installation prior to release of replacement parts, unit or labor reimbursement. All claims must be validated and approved by an authorized Stream33 representative.

#### **FULL FIRST YEAR LABOR**

If the Product or any part supplied by Stream33 fails due to defects in material or workmanship within the first (1) year of purchase date by the PURCHASER, Stream33 will replace the defective part free of charge, including reasonable market labor allowances.

#### **THREE YEARS NON-RESIDENTIAL APPLICATION**

If the Product supplied by Stream33 installed in a “NON-Residential Application” fails due to defects in material or workmanship within the first three (3) years of purchase date by the PURCHASER, Stream33 will replace the defective part or replace the entire Product free of charge. “NON-Residential Application” refers to Product installed in any location other than homes (single or multi-family), apartments, duplexes, or condominiums used solely for personal, household, or family use.

#### **TEN YEARS RESIDENTIAL APPLICATION**

If the Product supplied by Stream33 installed in a “Residential Application” fails due to defects in material or workmanship within the first ten (10) years of purchase date by the PURCHASER, Stream33 will replace the defective part or replace the entire Product free of charge. “Residential Application” refers to Product installed in homes (single or multi-family), apartments, duplexes, or condominiums used solely for personal, household, or family use.

#### **REPLACEMENT WARRANTY**

All replacement water heaters and parts are covered under the remainder of the original warranty period. For example, if a water heater with a ten (10) year tank warranty develops a leak due to defects in materials or workmanship after nine (9) years, the replacement unit will only be covered for the remaining one (1) year of the original ten (10) year warranty.

#### **WHAT IS NOT COVERED?**

This Limited Warranty applies only to Stream33 Products that are installed by licensed contractors who are licensed for installation under applicable local and state laws (a “Licensed Contractor”), and where installation of the Product is completed in strict compliance with (A) all applicable building codes, ordinances, regulations and permits; (B) Stream33’s installation and

operation instructions; and (C) good trade practices (each of the foregoing, the "Warranty Conditions"). In the event the Product is not installed by a Licensed Contractor and in strict compliance with each of the Warranty Conditions, this Limited Warranty, and Stream33's obligations arising hereunder, shall be deemed null and void.

This Limited Warranty does not cover and Stream33 is not liable for, (i) installation charges and/or costs related to the defective Products and/or parts that occur outside of the labor required for warranty covered repair or replacement including shipping, delivery or freight charges; (ii) any labor charges and/or costs related to the defective Products and/or parts including removal charges and required permit fees; (iii) Products which have been damaged as a result of any accident, misuse, abuse, neglect, improper installation or maintenance, the use of abrasive or organic solvent cleaners, flood/water damage, removal of magnesium anode, use of fuels or settings not listed on rating plate or modification; (iv) Adverse conditions including atmospheric corrosive elements and lime precipitate or sediment in the tank; (v) failure to use the Product in accordance with the instructions provided by Stream33; (vi) Products not installed by a Licensed Contractor; (vii) Products not installed in strict compliance with the Warranty Conditions; and/or (viii) Products for which the Stream33 Registration have not been completed on or before the Registration Deadline.

#### **PRODUCT REGISTRATION**

This Limited Product Warranty, and Stream33's obligations arising pursuant to this Limited Warranty are expressly conditioned upon the Product being registered with Stream33 (the "Stream33 Registration") within the earlier of (i) sixty (60) days following date the equipment is first installed by a licensed contractor; or (ii) ninety (90) days from the date of purchase (the "Registration Deadline"). In the event the Stream33 Registration is not completed on or before the Registration Deadline, this Limited Warranty shall become null and void and of no further force and effect. Product can be registered online:



#### **WARRANTY RESPONSE**

If a defect occurs within the warranty period, at Stream33 manufacture discretion, we will (i) Provide a replacement part (or, at our authorization, replace) the unit during warranty period. To receive a replacement, you must have prior approval from an authorized Stream33 representative and an RGA reference number. If government regulations require the replacement water heater to include features not present in the defective unit, you will need to cover the cost difference for those required features or (ii) Provide a replacement part (or, at our discretion, repair) any part that fails to function within the parts warranty period. To obtain a replacement, you must send us the defective part. If government regulations require the replacement part to include features not present in the defective part, you will need to cover the cost difference for those required features. We reserve the right to verify any defect claims through inspection

#### **HOW TO OBTAIN WARRANTY SERVICE**

Complete the Warranty Claim Form to report the incident.



[stream33.com](http://stream33.com)

Return failed Product with proof of purchase, your name, and address within thirty (30) days of failure to:

Stream33 Products LLC  
ATTN: 33Brands Quality Team  
5700 Lee Road South  
Maple Heights, OH 44137

**LIMITATION OF LIABILITY**

Stream33's liability on any claim of any kind, including, without limitation, warranty, negligence and/or breach of contract, shall in no case exceed the purchase price paid by the Customer. IN NO EVENT SHALL STREAM33 BE LIABLE FOR ANY SPECIAL, INCIDENTAL, CONSEQUENTIAL (INCLUDING, WITHOUT LIMITATION, DAMAGE TO PROPERTY) OR PUNITIVE DAMAGES, DAMAGES IN THE NATURE OF PENALTIES OR SIMILAR OR RELATED DAMAGES OF ANY KIND.

**DISCLAIMER OF WARRANTIES**

STREAM33 EXPRESSLY DISCLAIMS ALL WARRANTIES, EXCEPT AS EXPLICITLY STATED HEREIN, TO THE FULLEST EXTENT PERMITTED BY LAW, WHETHER WRITTEN, ORAL, EXPRESS OR IMPLIED, INCLUDING ANY WARRANTY OF PERFORMANCE, MERCHANTABILITY, FITNESS FOR A PARTICULAR PURPOSE, AND NONINFRINGEMENT. THIS DISCLAIMER INCLUDES ANY ORAL WARRANTIES OR REPRESENTATIONS MADE OR IMPLIED BY ANY AGENT, EMPLOYEE, SUBCONTRACTOR, MANAGER, DIRECTOR AND/OR REPRESENTATIVE OF STREAM33.

